

Hydraulic Dampers

Multi-talent in speed control

The hydraulic dampers are similar in appearance to the ACE industrial gas springs but are adjusted in the end position and work differently to the DVC family with individual speed adjusters for the push and pull direction. This provide users with the maximum flexibility.

Whether used as drive compensation or safety elements, the retraction and extension speed of these ACE solutions can always be precisely set. This means that the speed of movement can be controlled, synchronisation regulated in both directions and pivoting loads can be compensated. Depending on the model, the push and pull forces are between 30 N and 40,000 N. These maintenance-free, ready-to-install products are available in body diameters of 12 mm to 70 mm and in stroke lengths up to 800 mm.



Hydraulic Dampers



DVC-32 and DVC-2 to DVC-6

Page 194

Adjustable, Without Free Travel

Multi-directional speed adjustment

Cylinder speed controls, Absorption control, Finishing and processing centres



HBD-15 to HBD-40

Page 196

Adjustable

Motion Control at the highest level

Finishing and processing centres, Machine housing, Hoods, Shutters



HB-12 to HB-70

Page 202

Adjustable

Linear motion control

Conveyor systems, Transport systems, Furniture industry, Locking systems

Constant speed rates

Sensitive adjustment

High quality and long lifetime

Easy to mount



DVC-32 and DVC-2 to DVC-6

Multi-directional speed adjustment

Adjustable, Without Free Travel

Compression and extension force 42 N to 2,000 N

Stroke 50 mm to 150 mm

Separately regulated in any stroke position: The hydraulic dampers of the product family DVC-32 and DVC-2 to DVC-6 are the first dampers to provide precise, independent, external adjustment of in-and-out speeds. With their individual adjustments for the push and pull direction as well as the bi-directional action, these are suitable as safety or control elements.

The great number of mounting accessories makes assembly of these ACE hydraulic dampers easier and allows these maintenance-free, ready-to-install and self-contained systems universally applicable. Qualitatively high grade, and at the same time simple to use; one of their uses is to absorb swinging loads.

These velocity controllers are used in the automotive sector, automation and machine building as well as in the electronics industry.

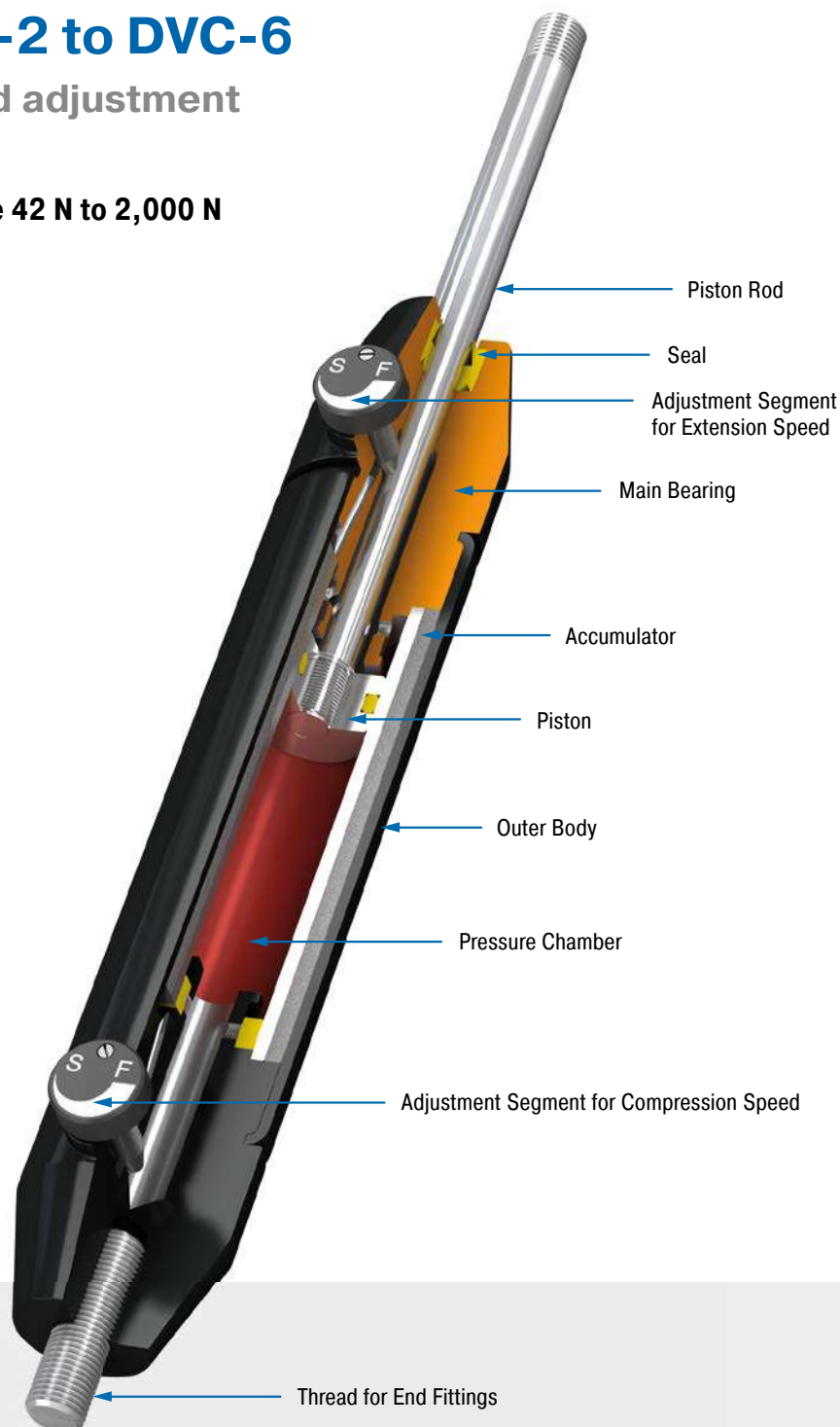

Technical Data

Compression and extension force: 42 N to 2,000 N

Outer body diameter: Ø 32 mm

Piston rod diameter: Ø 8 mm

Lifetime: Approx. 10,000 m

Operating temperature range: 0 °C to 65 °C

Adjustment: Steplessly adjustable

Positive stop: External positive stops 1 mm to 1.5 mm before the end of stroke provided by the customer.

Damping medium: Automatic Transmission Fluid (ATF)

Material: Outer body: Coated aluminium; Piston rod: Hard chrome plated steel; End fittings: Zinc plated steel

Mounting: In any position

Application field: Cylinder speed controls, Absorption control, Finishing and processing centres

Note: Increased break-away force if unit has not moved for some time. Damping force can be adjusted after installation.

End fittings: They are interchangeable and if necessary must be positively secured by the customer to prevent unscrewing.

On request: Special oils and other special options. Alternative accessories available on request.

Adjustable, Without Free Travel, Compression and extension force 42 N to 2,000 N

End Fitting

Standard Dimensions

End Fitting

A8

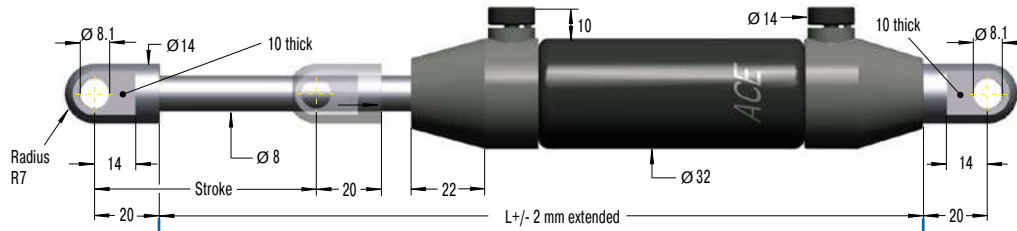

Eye A8
max. force 3,000 N

B8



Performance and Dimensions

TYPES	Stroke mm	L extended mm	¹ Compression force max. N
DVC-32-50	50	240	2,000
DVC-32-100	100	340	2,000
DVC-32-150	150	440	2,000

¹ Max. extension force for all stroke lengths 2,000 N.

Stud Thread B8

C8

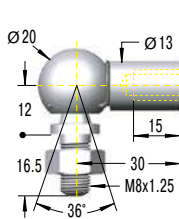

Angle Ball Joint C8
max. force 1,200 N

D8

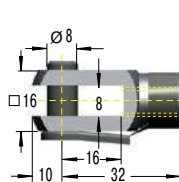

Clevis Fork D8
max. force 3,000 N

E8

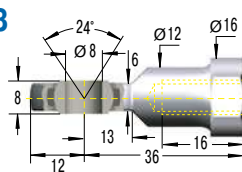

Swivel Eye E8
max. force 3,000 N

Ordering Example

DVC-32-50-DD-CCO

Type (Hydraulic Damper) _____
 Body \varnothing 1.26" (32 mm) omitted at DVC-2 to DVC-6 _____
 Stroke 2" (50 mm) _____
 Piston Rod End Fitting D8 _____
 Body End Fitting D8 _____
 Velocity Controls (Omit prefix for controlled, both directions) _____

Model Type Prefix

- : Controlled, both directions
 CCO: Controlled, compression only
 CTO: Controlled, tension only

End fittings: They are interchangeable and if necessary must be positively secured by the customer to prevent unscrewing.

Mounting accessories see from page 212.

DVC-2 to DVC-6

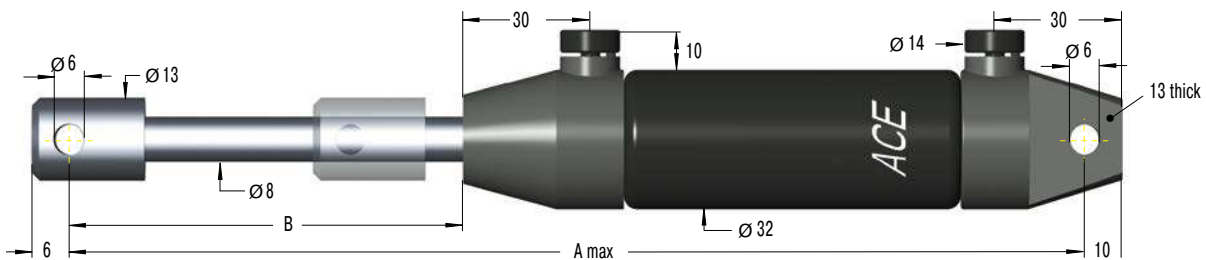

Performance and Dimensions

TYPES	Stroke mm	A max. mm	B mm	Compression force max. N	Traction force max. N
DVC-2	50	250	75.4	2,000	2,000
DVC-4	100	351	125	2,000	2,000
DVC-6	150	452	176	2,000	2,000

HBD-15 to HBD-40

Motion Control at the highest level

Adjustable

Compression and extension force 36 N to 10,000 N

Stroke 25 mm to 800 mm

ACE Controls HBD hydraulic dampers are maintenance-free, self-contained and sealed units. They are available with body diameters from 15 mm (0.59") to 40 mm (1.57") and with stroke lengths of up to 800 mm (31.5"). Unlike standard hydraulic dampers that include free travel up to 20 % of stroke, these dependable units have no free travel and are ideal for applications that require this level of performance. Double-acting hydraulic dampers are standard. However, a single acting design is available. Adjustment is easily achieved by pulling and turning the rod until the desired damping speed is achieved. The travel speed is adjustable and remains constant throughout the stroke.

The single acting version is controllable in one direction only, with free-flow in the opposite direction. A built-in antilock guard allows adjustment to be made at any damping rate without unit lock up. These reliable units offer long life-cycle performance. A variety of end fittings are available for ease of operation and installation, and are included.

HBD hydraulic dampers are used for process control, machine guards, lids, hatches, fire safety doors, arms for medical equipment, conveyors, swinging loads, machine tools, lift gates, drill feed control, amusement park rides, and more.

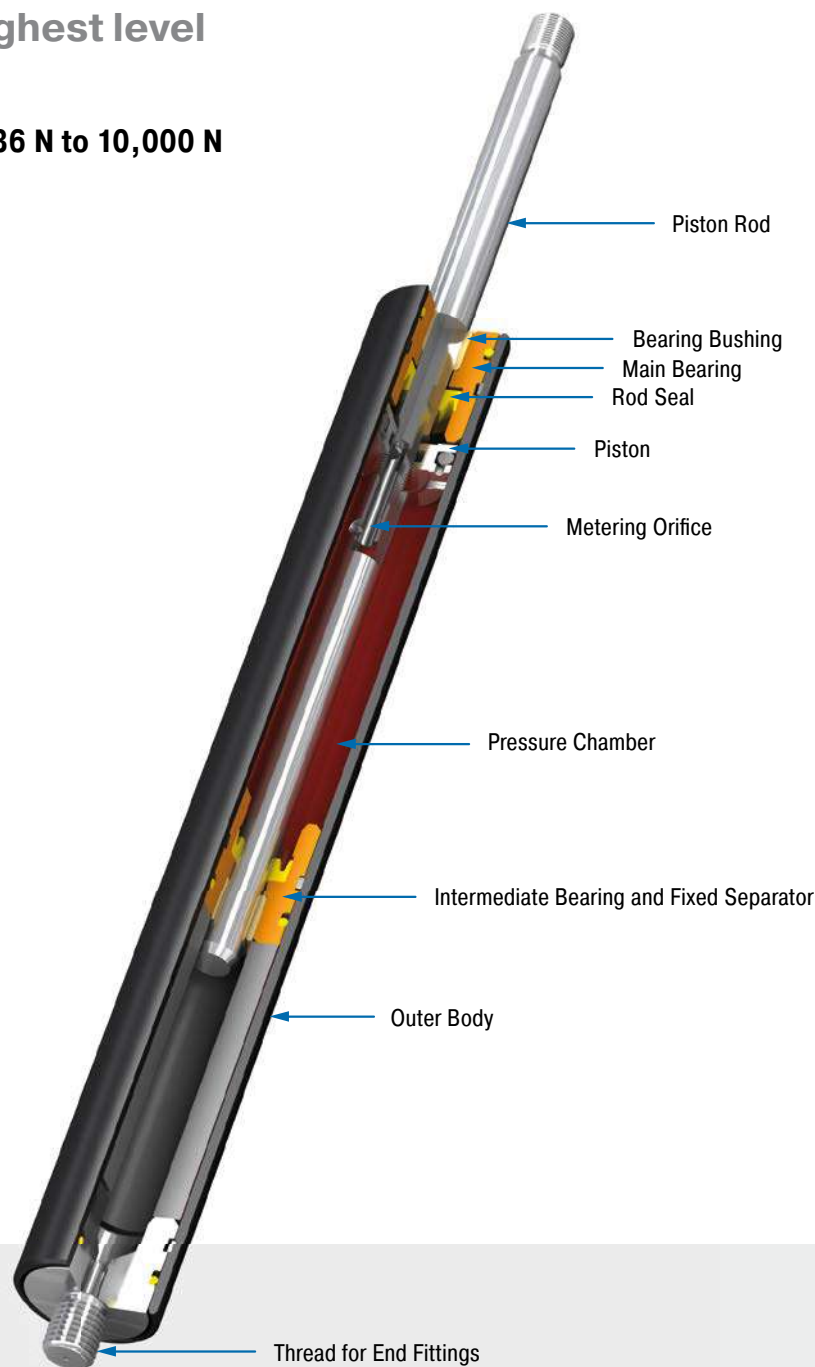

Technical Data

Compression and extension force: 36 N to 10,000 N

Outer body diameter: Ø 15 mm to Ø 40 mm

Piston rod diameter: Ø 6 mm to Ø 14 mm

Lifetime: Approx. 10,000 m

Free travel: These units have no free travel and are ideal for applications that require this level of performance.

Operating temperature range: -20 °C to 80 °C

Adjustment: Pull the piston rod out to its fully extended position. While pulling on the rod, turn it clockwise or counter-clockwise until the desired damping is achieved. The adjustment

is multi-turn and correct damping may require several trial and error adjustments. A built-in antilock guard allows adjustments to be made at any damping rate without unit lock up.

Positive stop: External positive stops 1 mm to 1.5 mm before the end of stroke provided by the customer.

Damping medium: Petroleum oil

Material: Outer body: Black anodized aluminium; Piston rod: Hard chrome plated steel; End fittings: Zinc plated steel

Mounting: In any position

Application field: Finishing and processing centers, Machine housing, Hoods, Shutters,

Fire safety doors, Medical technology, Conveyor systems, Swivel units, Tool machines, Lift doors

Note: Increased break-away force if unit has not moved for some time.

End fittings: They are interchangeable and if necessary must be positively secured by the customer to prevent unscrewing.

Safety information: Mechanical Stop required 1 mm to 1.5 mm before end of stroke.

On request: Special oils, damping characteristics, and stroke lengths. Alternative accessories available on request.

Adjustable, Compression and extension force 36 N to 800 N

End Fitting

Standard Dimensions

End Fitting

A5 Eye A5 max. force 800 N

B5 Stud Thread B5

C5 Angle Ball Joint C5 max. force 500 N

D5 Clevis Fork D5 max. force 800 N

E5 Swivel Eye E5 max. force 800 N

Stroke

L +/- 2 extended + max 6 at maximum adjustment

Performance and Dimensions

TYPES	Stroke mm	L extended mm	¹ Compression force max. N
HBD-15-25	25	145	800
HBD-15-50	50	220	800
HBD-15-75	75	295	800
HBD-15-100	100	370	350
HBD-15-150	150	520	300

¹ Max. extension force for all stroke lengths 800 N.

Ordering Example

HBD-15-150-AA-P

Type (Hydraulic Damper) _____

Body 0.59" (15 mm) _____

Stroke 5.91" (150 mm) _____

Piston Rod End Fitting A5 _____

Body End Fitting A5 _____

Damping Direction (P = in both directions) _____

Model Type Prefix

P = Damping in both directions
 N = Damping on in stroke only
 M = Damping on out stroke only
 X = Special model suffix

Mounting accessories see from page 212.

HBD-15

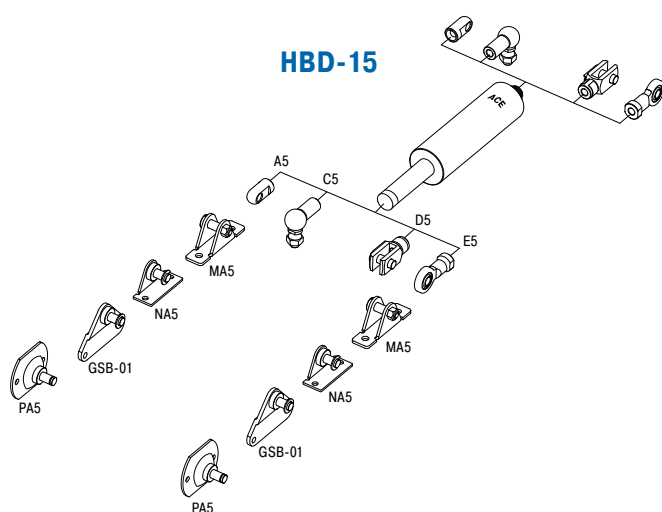

Technical Data

Compression and extension force: 36 N to 800 N

Free travel: These units have no free travel and are ideal for applications that require this level of performance.

Operating temperature range: -20 °C to 80 °C

Adjustment: Pull the piston rod out to its fully extended position. While pulling on the rod, turn it clockwise or counter-clockwise until the desired damping is achieved. The adjustment is multi-turn and correct damping may require several trial and error adjustments. A built-in antilock guard allows adjustments to be made at any damping rate without unit lock up.

Material: Outer body: Black anodized aluminium; Piston rod: Hard chrome plated steel; End fittings: Zinc plated steel

Mounting: In any position

End fittings: They are interchangeable and if necessary must be positively secured by the customer to prevent unscrewing.

Safety information: Mechanical Stop required 1 mm to 1.5 mm before end of stroke.

Adjustable, Compression and extension force 50 N to 1,800 N

End Fitting

Standard Dimensions

End Fitting

A8

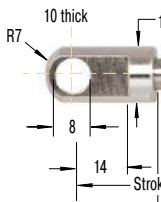

B8



C8

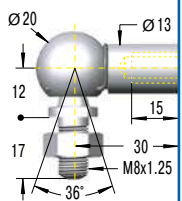

D8

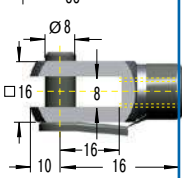

E8

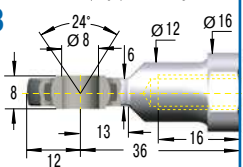

Eye A8
max. force 3,000 N

Stud Thread B8

Angle Ball Joint C8
max. force 1,200 N

Clevis Fork D8
max. force 3,000 N

Swivel Eye E8
max. force 3,000 N

Performance and Dimensions

TYPES	Stroke mm	L extended mm	1 Compression force max. N
HBD-22-50	50	238	1,800
HBD-22-100	100	385	1,800
HBD-22-150	150	525	1,800
HBD-22-200	200	685	1,000
HBD-22-250	250	835	1,000
HBD-22-300	300	985	800
HBD-22-350	350	1,135	600
HBD-22-400	400	1,285	400

1 Max. extension force for all stroke lengths 1,800 N.

Ordering Example

Type (Hydraulic Damper) _____
 Body 0.87" (22 mm) _____
 Stroke 5.90" (150 mm) _____
 Piston Rod End Fitting A8 _____
 Body End Fitting A8 _____
 Damping Direction (P = in both directions) _____

HBD-22-150-AA-P

Model Type Prefix

- P = Damping in both directions
- N = Damping on in stroke only
- M = Damping on out stroke only
- X = Special model suffix

Mounting accessories see from page 212.

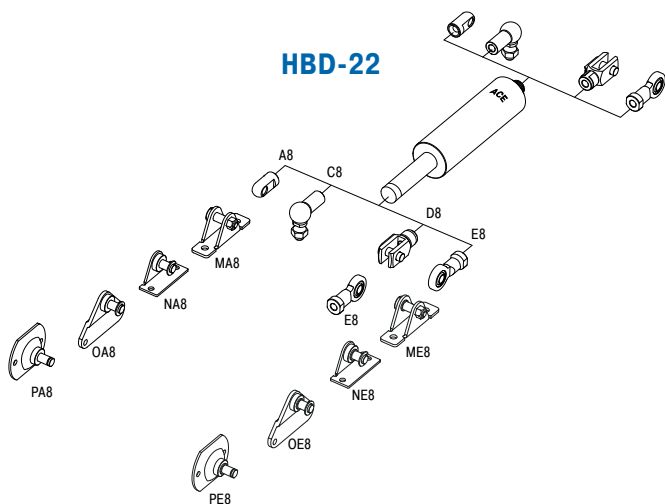

Technical Data

Compression and extension force: 50 N to 1,800 N

Free travel: These units have no free travel and are ideal for applications that require this level of performance.

Operating temperature range: -20 °C to 80 °C

Adjustment: Pull the piston rod out to its fully extended position. While pulling on the rod, turn it clockwise or counter-clockwise until the desired damping is achieved. The adjustment is multi-turn and correct damping may require several trial and error adjustments. A built-in antilock guard allows adjustments to be made at any damping rate without unit lock up.

Material: Outer body: Black anodized aluminium; Piston rod: Hard chrome plated steel; End fittings: Zinc plated steel

Mounting: In any position

End fittings: They are interchangeable and if necessary must be positively secured by the customer to prevent unscrewing.

Safety information: Mechanical Stop required 1 mm to 1.5 mm before end of stroke.

Adjustable, Compression and extension force 70 N to 3,000 N

End Fitting

Standard Dimensions

End Fitting

A8

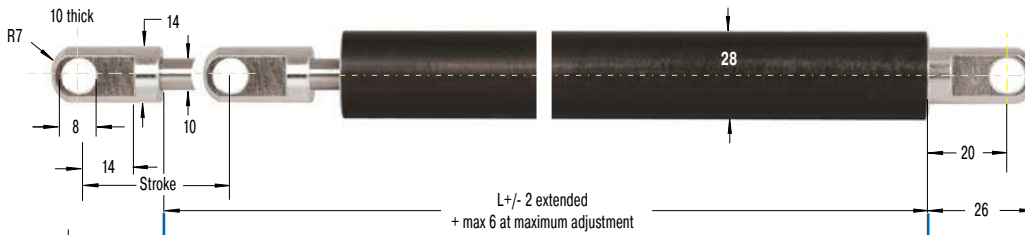

Eye A8
max. force 3,000 N

B8



Performance and Dimensions

TYPES	Stroke mm	L extended mm	¹ Compression force max. N
HBD-28-50	50	250	3,000
HBD-28-100	100	400	3,000
HBD-28-150	150	550	3,000
HBD-28-200	200	700	3,000
HBD-28-250	250	850	3,000
HBD-28-300	300	1,000	2,500
HBD-28-350	350	1,150	2,000
HBD-28-400	400	1,300	1,500
HBD-28-500	500	1,600	1,000

¹ Max. extension force for all stroke lengths 3,000 N.

Stud Thread B8

C8

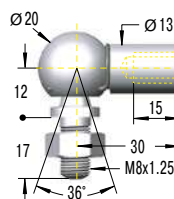

Angle Ball Joint C8
max. force 1,200 N

D8

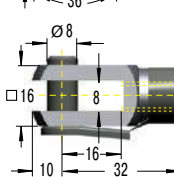

Clevis Fork D8
max. force 3,000 N

E8

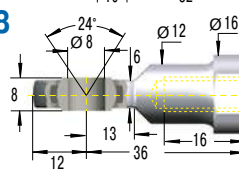

Swivel Eye E8
max. force 3,000 N

Ordering Example

HBD-28-150-AA-P

Type (Hydraulic Damper) _____
 Body 1.10" (28 mm) _____
 Stroke 5.91" (150 mm) _____
 Piston Rod End Fitting A8 _____
 Body End Fitting A8 _____
 Damping Direction (P = in both directions) _____

Model Type Prefix

- P = Damping in both directions
- N = Damping on in stroke only
- M = Damping on out stroke only
- X = Special model suffix

Mounting accessories see from page 212.

Technical Data

Compression and extension force: 70 N to 3,000 N

Free travel: These units have no free travel and are ideal for applications that require this level of performance.

Operating temperature range: -4 °F to 176 °F

Adjustment: Pull the piston rod out to its fully extended position. While pulling on the rod, turn it clockwise or counter-clockwise until the desired damping is achieved. The adjustment is multi-turn and correct damping may require several trial and error adjustments. A built-in antilock guard allows adjustments to be made at any damping rate without unit lock up.

Material: Outer body: Black anodized aluminium; Piston rod: Hard chrome plated steel; End fittings: Zinc plated steel

Mounting: In any position

End fittings: They are interchangeable and if necessary must be positively secured by the customer to prevent unscrewing.

Safety information: Mechanical Stop required 1 mm to 1.5 mm before end of stroke.

HBD-28

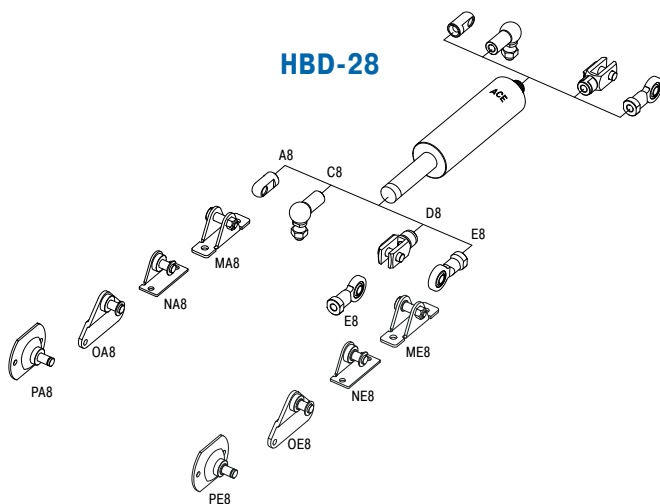

Adjustable, Compression and extension force 80 N to 10,000 N

End Fitting

Standard Dimensions

End Fitting

Performance and Dimensions

TYPES	Stroke mm	L extended mm	¹ Compression force max. N
HBD-40-100	100	430	10,000
HBD-40-150	150	580	10,000
HBD-40-200	200	730	10,000
HBD-40-300	300	1,030	10,000
HBD-40-400	400	1,330	8,000
HBD-40-500	500	1,630	6,000
HBD-40-600	600	1,930	4,000
HBD-40-700	700	2,230	3,000
HBD-40-800	800	2,530	2,000

¹ Max. extension force for all stroke lengths 10,000 N.

Ordering Example

HBD-40-300-AA-P

Type (Hydraulic Damper) _____
 Body 1.57" (40 mm) _____
 Stroke 11.81" (300 mm) _____
 Piston Rod End Fitting A14 _____
 Body End Fitting A14 _____
 Damping Direction (P = in both directions) _____

Model Type Prefix

P = Damping in both directions
 N = Damping on in stroke only
 M = Damping on out stroke only
 X = Special model suffix

Mounting accessories see from page 212.

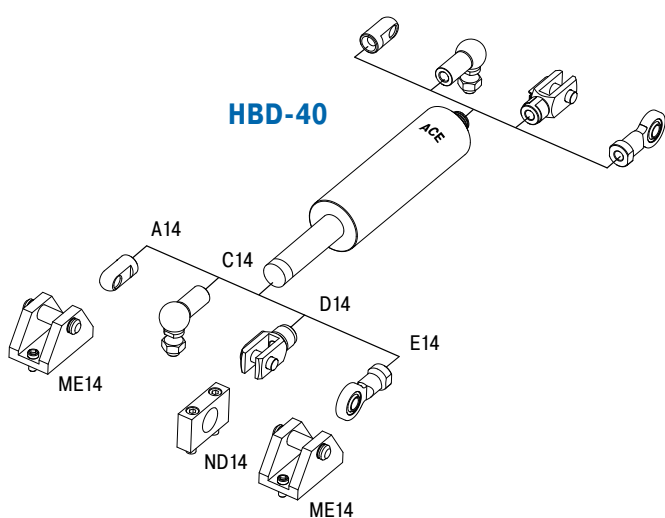

Technical Data

Compression and extension force: 80 N to 10,000 N

Free travel: These units have no free travel and are ideal for applications that require this level of performance.

Operating temperature range: -20 °C to 80 °C

Adjustment: Pull the piston rod out to its fully extended position. While pulling on the rod, turn it clockwise or counter-clockwise until the desired damping is achieved. The adjustment is multi-turn and correct damping may require several trial and error adjustments. A built-in antilock guard allows adjustments to be made at any damping rate without unit lock up.

Material: Outer body: Black anodized aluminium; Piston rod: Hard chrome plated steel; End fittings: Zinc plated steel

Mounting: In any position

End fittings: They are interchangeable and if necessary must be positively secured by the customer to prevent unscrewing.

Safety information: Mechanical Stop required 1 mm to 1.5 mm before end of stroke.

Dream it

We. Love. Challenges.



Ok, pure gold or fur-covered are not realistic options.
But if you need a perfect solution for your individual needs, ACE has the tools and expertise to make it happen.

Call our experts
+1 800-521-3220 or go to www.acecontrols.com

HB- 12 to HB-70

Linear motion control

Adjustable

Compression and extension force 20 N to 50,000 N

Stroke 10 mm to 800 mm

High quality and long service life: The hydraulic dampers of the product family HB can also be used as single or double acting brake. Its coated body and piston rods with wear-resistant surface treatment are features of high quality and long service life.

The maintenance free, ready-to-install and closed systems provide a constant feed rate and are adjustable. The control segment on the piston makes adjustment at the end position child's play. Thanks to a broad selection of end fittings the assembly is easy to mount, so that the damper can be universally deployed for damping swinging masses, such as in power or free conveyors.

On automotive, automation and machine building, medical technology or the electronics and furniture industry, these machine elements are found in a number of different areas.

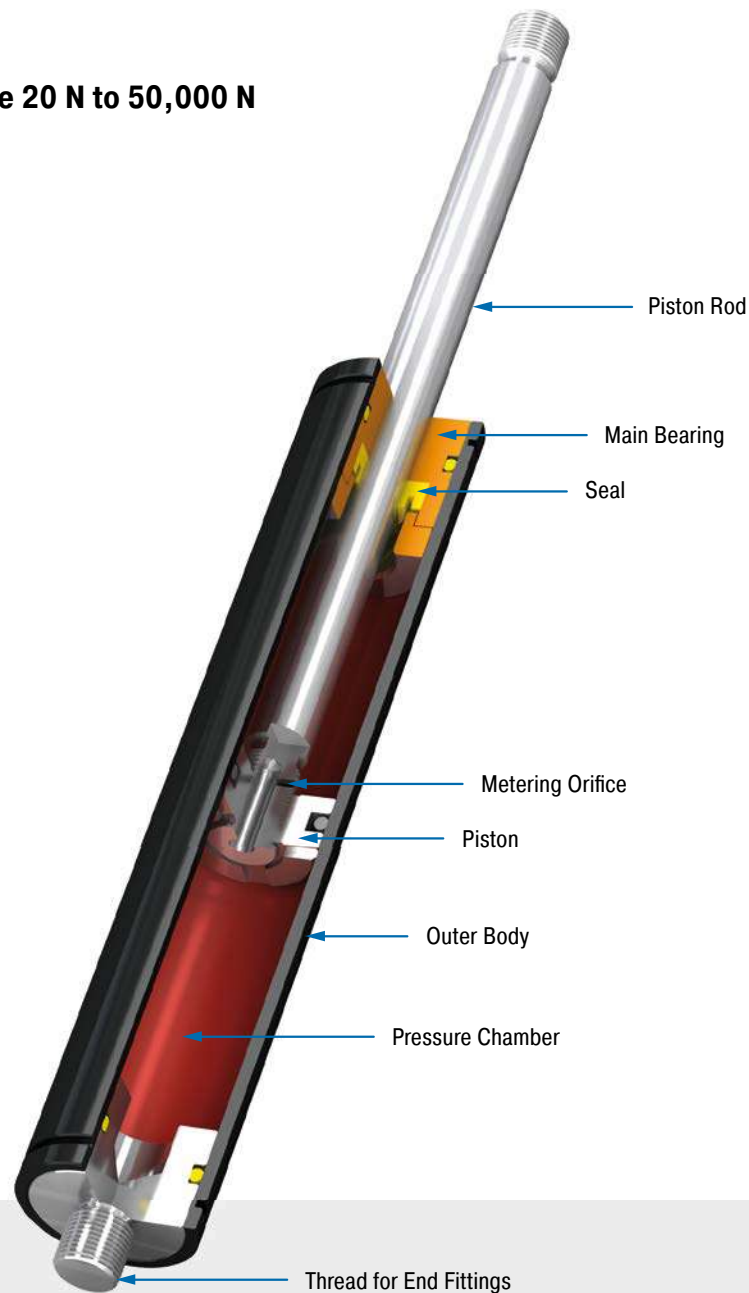

Technical Data

Compression and extension force: 20 N to 50,000 N

Outer body diameter: Ø 12 mm to Ø 70 mm

Piston rod diameter: Ø 4 mm to Ø 30 mm

Lifetime: Approx. 10,000 m

Free travel: Construction of the damper results in a free travel of approx. 20 % of stroke.

Separator piston: Available as a special option without free travel achieved by separator piston and nitrogen accumulator.

Operating temperature range: -20 °C to 80 °C

Adjustment: Achieved by turning the piston rod in its fully extended or fully compressed position.

Positive stop: External positive stops 1 mm to 6 mm before the end of stroke provided by the customer.

Damping medium: Hydraulic oil

Material: Outer body: Coated steel; Piston rod: Steel or stainless steel with wear-resistant coating; End fittings: Zinc plated steel

Mounting: In any position

Application field: Conveyor systems, Transport systems, Furniture industry, Locking systems, Sports equipment

Note: Increased break-away force if unit has not moved for some time.

End fittings: They are interchangeable and if necessary must be positively secured by the customer to prevent unscrewing.

On request: Special oils and other special options. Alternative accessories available on request.

Adjustable, Compression and extension force 20 N to 180 N

End Fitting
Standard Dimensions
End Fitting
A3.5

Eye A3.5
max. force 370 N

B3.5

Performance and Dimensions

TYPES	Stroke mm	L extended mm	¹ Compression force max. N
HB-12-10	10	55	180
HB-12-20	20	75	180
HB-12-30	30	95	180
HB-12-40	40	115	180
HB-12-50	50	135	180
HB-12-60	60	155	180
HB-12-70	70	175	180
HB-12-80	80	195	150

¹ Max. extension force for all stroke lengths 180 N.

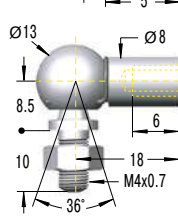
Stud Thread B3.5
C3.5

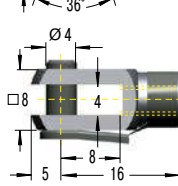
Angle Ball Joint C3.5
max. force 370 N

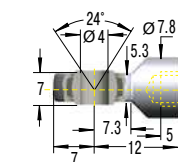
D3.5

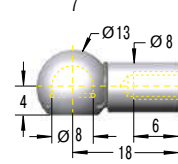
Clevis Fork D3.5
max. force 370 N

E3.5

Swivel Eye E3.5
max. force 370 N

G3.5

Ball Socket G3.5
max. force 370 N

Ordering Example

Type (Hydraulic Damper) _____
 Body 0.47" (12 mm) _____
 Stroke 1.18" (30 mm) _____
 Piston Rod End Fitting A3.5 _____
 Body End Fitting C3.5 _____
 Damping Direction (M = out stroke only) _____

HB-12-30-AC-M
Model Type Prefix

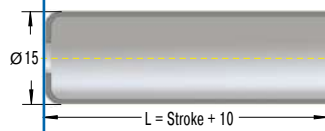
P: Damping in both directions
 N: Damping on in stroke only
 M: Damping on out stroke only
 X: Special model suffix

Mounting accessories see from page 212.
Rod Shroud W3.5-12

Technical Data
Compression and extension force: 20 N to 180 N

Free travel: Construction of the damper results in a free travel of approx. 21 % of stroke.

Separator piston: Available as a special option without free travel achieved by separator piston and nitrogen accumulator.

Operating temperature range: -20 °C to 80 °C

Adjustment: Achieved by turning the piston rod in its fully extended or fully compressed position.

Clockwise rotation = increase of the damping

Anti-clockwise rotation = decrease of the damping

Damping force adjustable before installation. Adjustment can add a max. of 6 mm to the L dimension.

Positive stop: External positive stops 1 mm to 1.5 mm before the end of stroke provided by the customer.

Material: Outer body: Coated steel; Piston rod: Stainless steel (1.4301/1.4305, AISI 304/303); End fittings: Zinc plated steel

Mounting: In any position

Note: Increased break-away force if unit has not moved for some time.

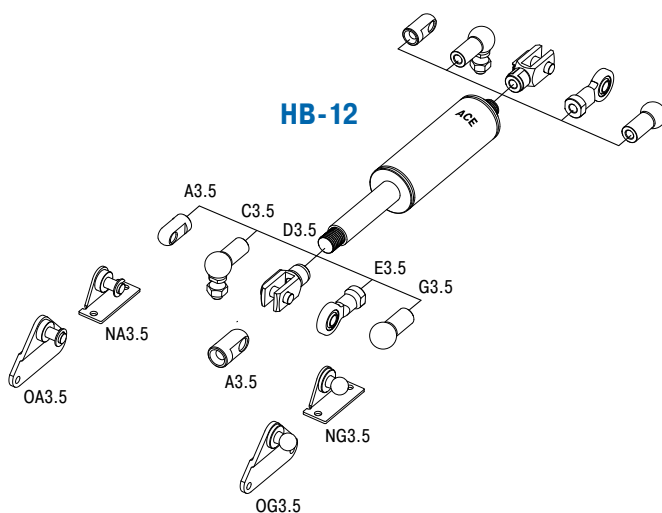
End fittings: They are interchangeable and if necessary must be positively secured by the customer to prevent unscrewing.

Adjustable, Compression and extension force 20 N to 800 N

End Fitting

Standard Dimensions

End Fitting

Performance and Dimensions

TYPES	Stroke mm	L extended mm	¹ Compression force max. N
HB-15-25	25	93	800
HB-15-50	50	143	800
HB-15-75	75	193	800
HB-15-100	100	243	350
HB-15-150	150	343	300

¹ Max. extension force for all stroke lengths 800 N.

Ordering Example

HB-15-150-AA-P

Type (Hydraulic Damper) _____
 Body 0.59" (15 mm) _____
 Stroke 5.91" (150 mm) _____
 Piston Rod End Fitting A5 _____
 Body End Fitting A5 _____
 Damping Direction (P = in both directions) _____

Model Type Prefix

P: Damping in both directions
 N: Damping on in stroke only
 M: Damping on out stroke only
 X: Special model suffix

Mounting accessories see from page 212.

Technical Data

- Compression and extension force:** 20 N to 800 N
- Free travel:** Construction of the damper results in a free travel of approx. 20 % of stroke.
- Separator piston:** Available as a special option without free travel achieved by separator piston and nitrogen accumulator.
- Operating temperature range:** -20 °C to 80 °C
- Adjustment:** Achieved by turning the piston rod in its fully extended or fully compressed position.
 Clockwise rotation = increase of the damping
 Anti-clockwise rotation = decrease of the damping
 Damping force adjustable before installation. Adjustment can add a max. of 6 mm to the L dimension.
- Positive stop:** External positive stops 1 mm to 1.5 mm before the end of stroke provided by the customer.
- Material:** Outer body: Black anodized aluminium; Piston rod: Steel with wear-resistant coating; End fittings: Zinc plated steel
- Mounting:** In any position
- Note:** Increased break-away force if unit has not moved for some time.
- End fittings:** They are interchangeable and if necessary must be positively secured by the customer to prevent unscrewing.

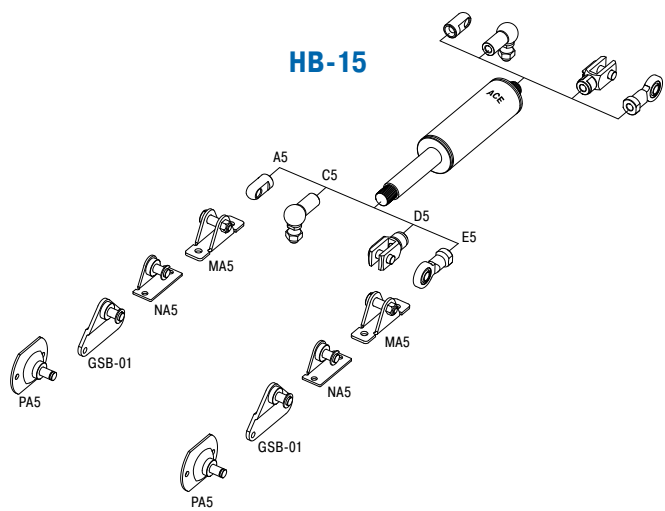

Adjustable, Compression and extension force 30 N to 1,800 N

End Fitting

Standard Dimensions

End Fitting

Performance and Dimensions

TYPES	Stroke mm	L extended mm	¹ Compression force max. N
HB-22-50	50	150	1,800
HB-22-100	100	250	1,800
HB-22-150	150	350	1,800
HB-22-200	200	450	1,000
HB-22-250	250	550	1,000
HB-22-300	300	650	800
HB-22-350	350	750	600
HB-22-400	400	850	400

¹ Max. extension force for all stroke lengths 1,800 N.

Ordering Example

HB-22-150-AA-P

- Type (Hydraulic Damper)
- Body 0.87" (22 mm)
- Stroke 5.90" (150 mm)
- Piston Rod End Fitting A8
- Body End Fitting A8
- Damping Direction (P = in both directions)

Model Type Prefix

- P: Damping in both directions
- N: Damping on in stroke only
- M: Damping on out stroke only
- X: Special model suffix

Mounting accessories see from page 212.

Technical Data

Compression and extension force: 30 N to 1,800 N

Free travel: Construction of the damper results in a free travel of approx. 20 % of stroke.

Separator piston: Available as a special option without free travel achieved by separator piston and nitrogen accumulator.

Operating temperature range: -20 °C to 80 °C

Adjustment: Achieved by turning the piston rod in its fully extended or fully compressed position.

Clockwise rotation = increase of the damping

Anti-clockwise rotation = decrease of the damping

Damping force adjustable before installation. Adjustment can add a max. of 6 mm to the L dimension.

Positive stop: External positive stops 1 mm to 1.5 mm before the end of stroke provided by the customer.

Material: Outer body: Black anodized aluminium; Piston rod: Steel with wear-resistant coating; End fittings: Zinc plated steel

Mounting: In any position

Note: Increased break-away force if unit has not moved for some time.

End fittings: They are interchangeable and if necessary must be positively secured by the customer to prevent unscrewing.

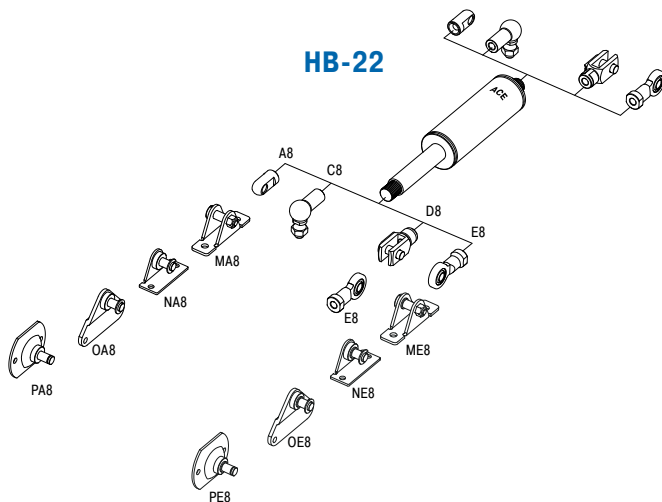

Adjustable, Compression and extension force 30 N to 3,000 N

End Fitting

Standard Dimensions

End Fitting

A8

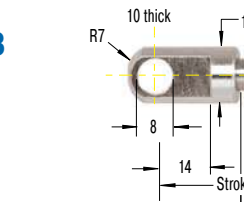

B8

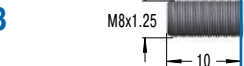

C8

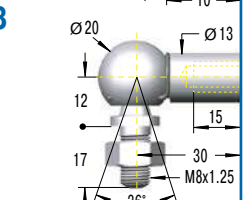

D8

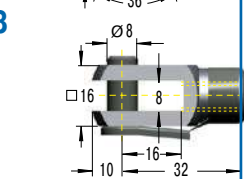

E8

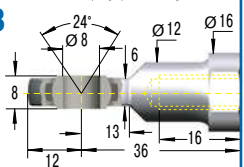

Eye A8
max. force 3,000 N

Stud Thread B8

Angle Ball Joint C8
max. force 1,200 N

Clevis Fork D8
max. force 3,000 N

Swivel Eye E8
max. force 3,000 N

Performance and Dimensions

TYPES	Stroke mm	L extended mm	¹ Compression force max. N
HB-28-50	50	160	3,000
HB-28-100	100	260	3,000
HB-28-150	150	360	3,000
HB-28-200	200	460	3,000
HB-28-250	250	560	3,000
HB-28-300	300	660	2,500
HB-28-350	350	760	2,000
HB-28-400	400	860	1,500
HB-28-500	500	1,060	1,000

¹ Max. extension force for all stroke lengths 3,000 N.

Ordering Example

Type (Hydraulic Damper) _____
 Body 1.10" (28 mm) _____
 Stroke 5.91" (150 mm) _____
 Piston Rod End Fitting A8 _____
 Body End Fitting A8 _____
 Damping Direction (P = in both directions) _____

HB-28-150-AA-P

Model Type Prefix

- P: Damping in both directions
- N: Damping on in stroke only
- M: Damping on out stroke only
- X: Special model suffix

Mounting accessories see from page 212.

Technical Data

Compression and extension force: 30 N to 3,000 N

Free travel: Construction of the damper results in a free travel of approx. 20 % of stroke.

Separator piston: Available as a special option without free travel achieved by separator piston and nitrogen accumulator.

Operating temperature range: -20 °C to 80 °C

Adjustment: Achieved by turning the piston rod in its fully extended or fully compressed position.

Clockwise rotation = increase of the damping

Anti-clockwise rotation = decrease of the damping

Damping force adjustable before installation. Adjustment can add a max. of 6 mm to the L dimension.

Positive stop: External positive stops 1 mm to 1.5 mm before the end of stroke provided by the customer.

Material: Outer body: Black anodized aluminium; Piston rod: Steel with wear-resistant coating; End fittings: Zinc plated steel

Mounting: In any position

Note: Increased break-away force if unit has not moved for some time.

End fittings: They are interchangeable and if necessary must be positively secured by the customer to prevent unscrewing.

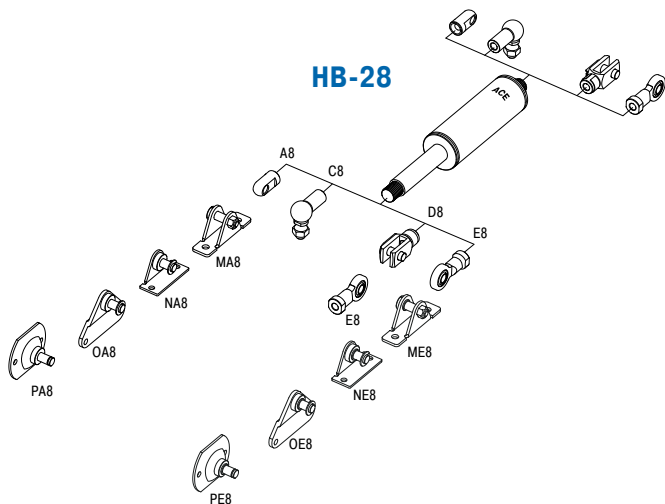

Adjustable, Compression and extension force 30 N to 10,000 N

End Fitting
Standard Dimensions
End Fitting

End Fitting A14
max. force 10,000 N

Eye A14
max. force 10,000 N

Stud Thread B14

Angle Ball Joint C14
max. force 3,200 N

Clevis Fork D14
max. force 10,000 N

Swivel Eye E14
max. force 10,000 N

Performance and Dimensions

TYPES	Stroke mm	L extended mm	¹ Compression force max. N
HB-40-100	100	275	10,000
HB-40-150	150	375	10,000
HB-40-200	200	475	10,000
HB-40-300	300	675	10,000
HB-40-400	400	875	8,000
HB-40-500	500	1,075	6,000
HB-40-600	600	1,275	4,000
HB-40-700	700	1,475	3,000
HB-40-800	800	1,675	3,000

¹ Max. extension force for all stroke lengths 10,000 N.

Ordering Example

HB-40-300-AA-P

Type (Hydraulic Damper) _____
 Body 1.57" (40 mm) _____
 Stroke 11.81" (300 mm) _____
 Piston Rod End Fitting A14 _____
 Body End Fitting A14 _____
 Damping Direction (P = in both directions) _____

Model Type Prefix

P: Damping in both directions
 N: Damping on in stroke only
 M: Damping on out stroke only
 X: Special model suffix

Mounting accessories see from page 212.

Technical Data
Compression and extension force: 30 N to 10,000 N

Free travel: Construction of the damper results in a free travel of approx. 20 % of stroke.

Separator piston: Available as a special option without free travel achieved by separator piston and nitrogen accumulator.

Operating temperature range: -20 °C to 80 °C

Adjustment: Achieved by turning the piston rod in its fully extended or fully compressed position.

Clockwise rotation = increase of the damping

Anti-clockwise rotation = decrease of the damping

Damping force adjustable before installation. Adjustment can add a max. of 6 mm to the L dimension.

Positive stop: External positive stops 1 mm to 1.5 mm before the end of stroke provided by the customer.

Material: Outer body: Black anodized aluminium; Piston rod: Steel with wear-resistant coating; End fittings: Zinc plated steel

Mounting: In any position

Note: Increased break-away force if unit has not moved for some time.

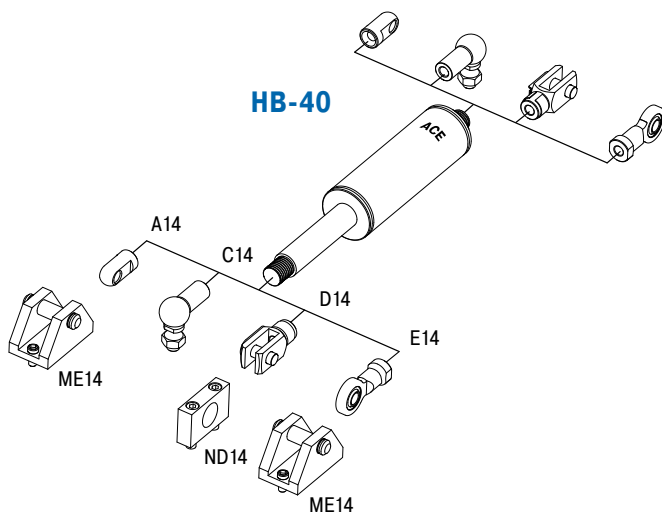
End fittings: They are interchangeable and if necessary must be positively secured by the customer to prevent unscrewing.

Adjustable, Compression and extension force 2,000 N to 50,000 N

End Fitting

Standard Dimensions

End Fitting

B24 Stud Thread **B24**

D24 Clevis Fork **D24**
max. force 50,000 N

E24 Swivel Eye **E24**
max. force 50,000 N

Performance and Dimensions

TYPES	Stroke mm	L extended mm	¹ Compression force max. N
HB-70-100	111	331	50,000
HB-70-200	211	531	50,000
HB-70-300	311	731	50,000
HB-70-400	411	931	30,300
HB-70-500	511	1,131	21,600
HB-70-600	611	1,331	16,200
HB-70-700	711	1,531	12,600
HB-70-800	811	1,731	10,100

¹ Max. extension force for all stroke lengths 50,000 N.

Ordering Example

HB-70-300-EE-N

Type (Hydraulic Damper) _____
 Body 2.76" (70 mm) _____
 Stroke 11.81" (300 mm) _____
 Piston Rod End Fitting E24 _____
 Body End Fitting E24 _____
 Damping Direction (N = in stroke only) _____

Model Type Prefix

P: Damping in both directions
 N: Damping on in stroke only
 M: Damping on out stroke only
 X: Special model suffix

Mounting accessories see from page 212.

Rod Shroud W24-70

Technical Data

Compression and extension force: 2,000 N to 50,000 N

Free travel: Construction of the damper results in a free travel of approx. 20 % of stroke.

Separator piston: Available as a special option without free travel achieved by separator piston and nitrogen accumulator.

Operating temperature range: -20 °C to 80 °C

Adjustment: Achieved by turning the piston rod in its fully extended or fully compressed position.

Clockwise rotation = increase of the damping

Anti-clockwise rotation = decrease of the damping

Damping force adjustable before installation. The adjustment can add a max. of 5 mm to the L dimension.

Positive stop: External positive stops 5 mm to 6 mm before the end of stroke provided by the customer.

Material: Outer body: Coated steel; Piston rod: Hard chrome plated steel; End fittings: Zinc plated steel

Mounting: In any position

Note: Increased break-away force if unit has not moved for some time.

End fittings: They are interchangeable and if necessary must be positively secured by the customer to prevent unscrewing.

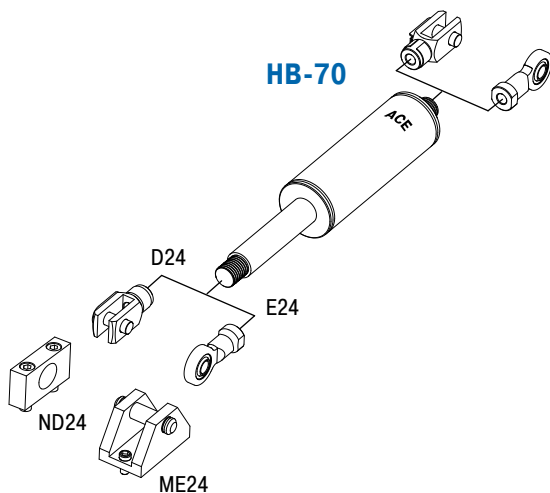

ACE Digital Tools



For more information about the calculation service see page 188!

Print catalog? Everyone can.

ACE offers more:

- ▶ Downloads: Product information in many languages
- ▶ PC calculation software & online calculation service
- ▶ Extensive CAD component libraries
- ▶ ACE-YouTube channel with video tips
- ▶ VibroChecker – free award-winning iPhone App

All available at www.acecontrols.com

Application Examples

DVC-32

Precise unreeling

Hydraulic dampers bring the sled movement of this textile machine to a gentle stop. At the turning point of 130 kg reeling spools, a sled should move up and down smoothly without causing a collision at the end of stroke position. The solution was provided by the hydraulic damper DVC-32-100. A self-contained sealed unit, ready to install and maintenance-free these units are ideal for precise control of speeds in both directions of travel. The travel speed is maintained throughout the entire stroke and can be independently adjusted in each direction of travel. Thanks to their compact design and wide choice of mounting accessories, these dampers could be easily integrated into this machine.

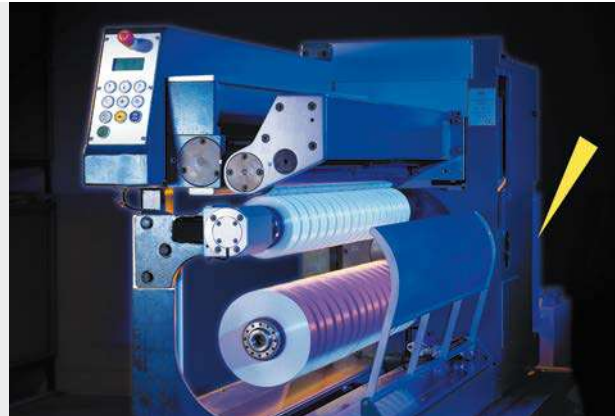
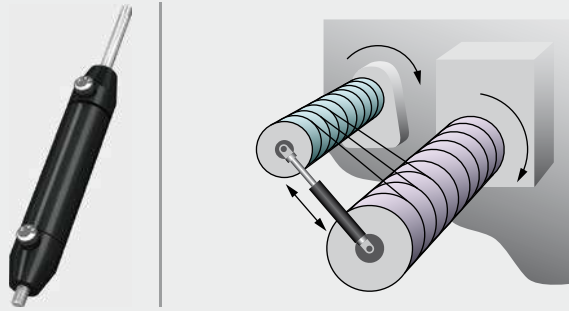

Textile machine unreels threads even better

HB-15

Operating speed of flaps top-regulated

In the past, operators of used-clothes containers could sustain injury because the flaps closed relatively quickly and uncontrollably. Various hydraulic dampers of the type HB-15, which are designed specifically for the type of container, regulate the synchronization of the flap in both directions and thereby serve to regulate the operating speed. To accommodate a range of requirements and to provide optimal protection against theft, different types with different strokes are mounted on flaps without damping, on large flaps with damping and on rotor flaps with damping.

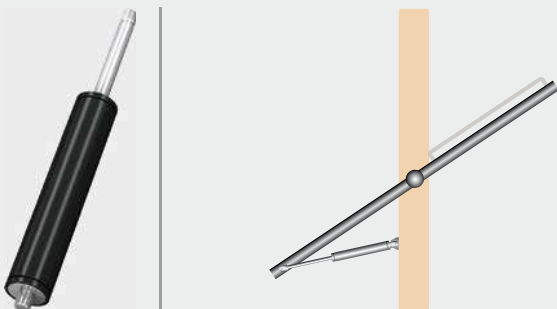

Hydraulic dampers prevent fingers becoming trapped in used-clothes containers as they ensure more gentle opening and closing movements
MCB Milieu & Techniek BV, 4704 SE Roosendaal, Netherlands

HB-40

Swinging movements cushioned by hydraulic dampers

Passengers always feel the swinging movement involved when cable cars arrive at the ski station. Maintenance-free hydraulic dampers type HB-40-300-EE-X-P cushion these movements perfectly. Designers of the cable cars, connected by means of an articulated joint via a four-point frame and connection guide to the suspension rod, profit from the ability of the adjustable dampers to absorb compressive forces of up to 10,000 N on either side.



Hydraulic dampers for added convenience when operating cable cars

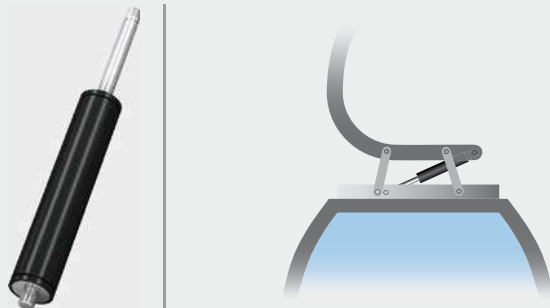

Mounting Accessories for steel gas springs and hydraulic dampers

By taking advantage of the very extensive range of ACE end fittings and mounting brackets you can easily and simply install our gas springs and hydraulic dampers. You profit from the variety of DIN standard end fittings such as swivel eyes, clevis forks, angle ball joints, inline ball joints, and included ball sockets.

ACE also offers eye fittings made of wear-resistant steel to meet the higher specification requirements found in industrial applications. With over 30 different types available these mounting accessories provide an extensive range of combinations for optimum installations.

With the ACE selection program you can choose not only your ACE gas springs but also the ideal end fittings and mounting brackets for your individual application example.

The complete range of accessories are also available as individual components.

**Infinite
Combinations!**

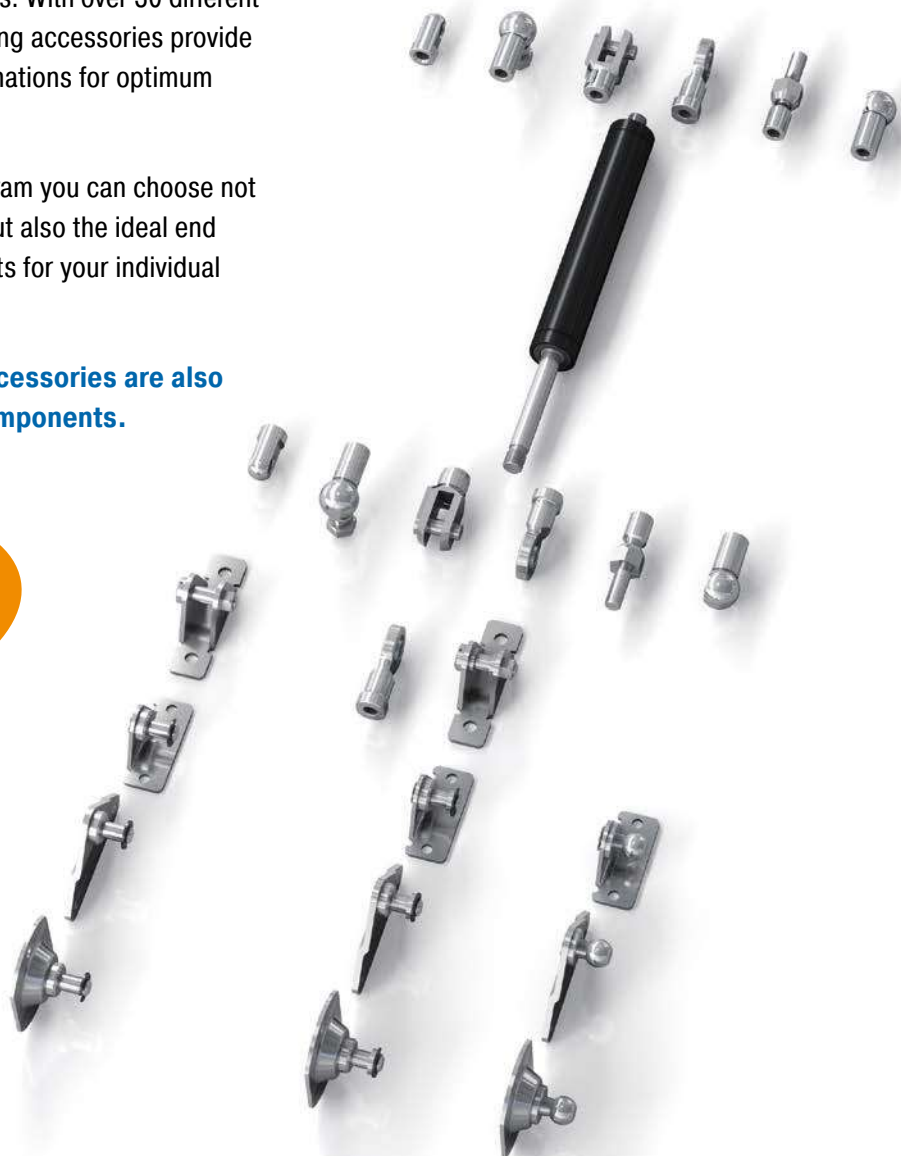

M3.5x0.6 (for GS-8, GS-10, GS-12, GZ-15, HB-12)

C3.5

Angle Ball Joint
DIN 71802

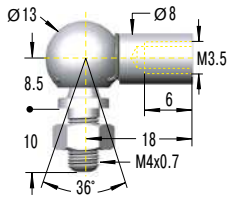

¹ max. force 370 N

E3.5

Swivel Eye
DIN 648

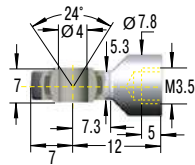

¹ max. force 370 N

A3.5

Eye

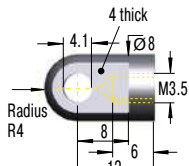

¹ max. force 370 N

NA3.5

Angle Bracket

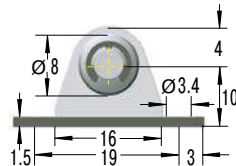

¹ max. force 180 N

OA3.5

Side Bracket

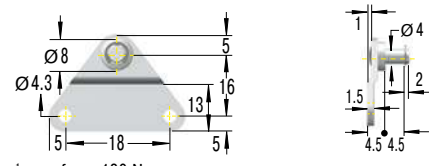

¹ max. force 180 N

D3.5

Clevis Fork
DIN 71752

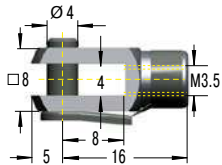

¹ max. force 370 N

A3.5

Eye

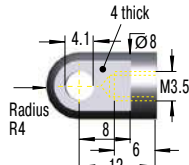

¹ max. force 370 N

G3.5

Ball Socket
DIN 71805

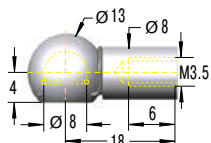

¹ max. force 370 N

NG3.5

Angle Bracket

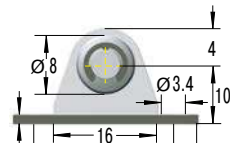

¹ max. force 180 N

OG3.5

Side Bracket

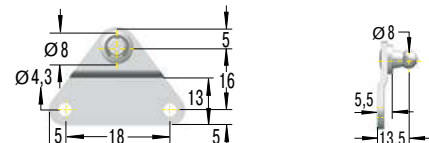

¹ max. force 180 N

¹ Attention! Max. static load in Newtons. Beware force increase during compression (progression) and observe max. force limit.

M5x0.8 (for GS-15, HBD-15, HB-15)

C5
Angle Ball Joint
DIN 71802

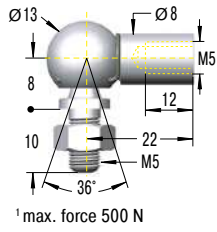

¹ max. force 500 N

D5
Clevis Fork
DIN 71752

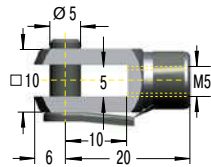

¹ max. force 800 N

F5
Inline Ball Joint

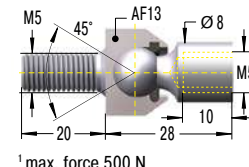

¹ max. force 500 N

Attention! Must only be used with compression loads!

A5
Eye

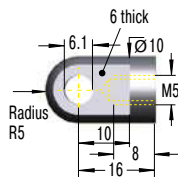

¹ max. force 800 N

MA5
Bearing Shoe

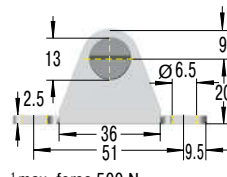

¹ max. force 500 N

NA5
Angle Bracket

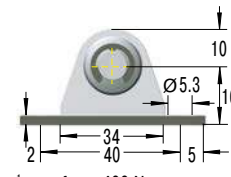

¹ max. force 400 N

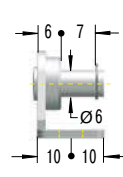

E5
Swivel Eye
DIN 648

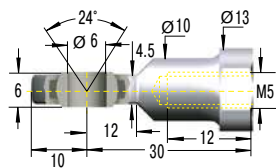

¹ max. force 800 N

GSB-01
Side Bracket

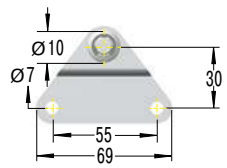

¹ max. force 500 N

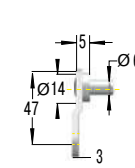

PA5
Round Bracket



¹ max. force 500 N



G5
Ball Socket
DIN 71805

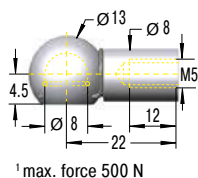

¹ max. force 500 N

NG5
Angle Bracket

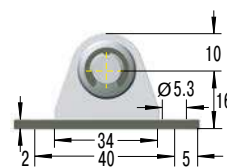

¹ max. force 400 N

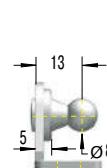

GSB-02
Side Bracket

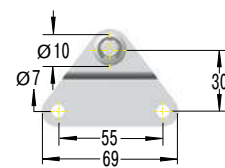

¹ max. force 500 N

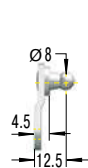

PG5
Round Bracket



¹ max. force 500 N



¹ Attention! Max. static load in Newtons. Beware force increase during compression (progression) and observe max. force limit.

M8x1.25

(for GS-19, GS-22, GZ-19, HBD-22, HBD-28, HB-22, HB-28, DVC-32)

C8

Angle Ball Joint
DIN 71802

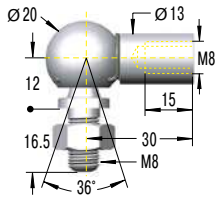

¹ max. force 1,200 N

F8

Inline Ball Joint

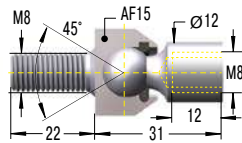

¹ max. force 1,200 N

Attention! Must only be used with compression loads!

A8

Eye

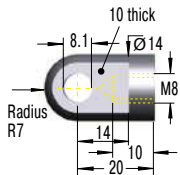

¹ max. force 3,000 N

MA8

Bearing Shoe

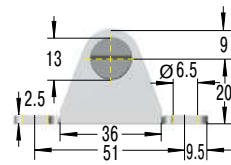

¹ max. force 1,800 N

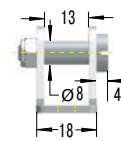

NA8

Angle Bracket

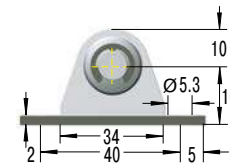

¹ max. force 1,000 N

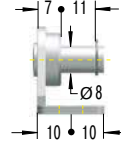

OA8

Side Bracket

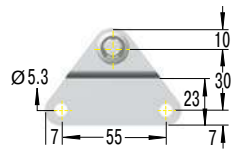

¹ max. force 1,200 N

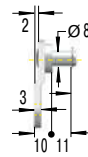

PA8

Round Bracket

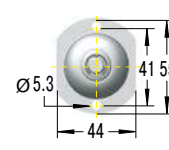

¹ max. force 1,200 N

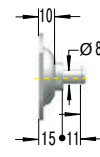

D8

Clevis Fork
DIN 71752

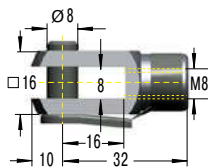

¹ max. force 3,000 N



E8

Swivel Eye
DIN 648

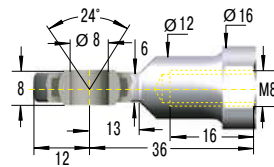

¹ max. force 3,000 N

¹ Attention! Max. static load in Newtons. Beware force increase during compression (progression) and observe max. force limit.

M8x1.25 (for GS-19, GS-22, GZ-19, HBD-22, HBD-28, HB-22, HB-28, DVC-32)

E8
Swivel Eye
DIN 648

¹ max. force 3,000 N



ME8
Bearing Shoe

¹ max. force 1,800 N

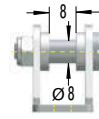

NE8
Angle Bracket

¹ max. force 1,000 N

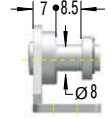

OE8
Side Bracket

¹ max. force 1,200 N

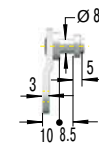

PE8
Round Bracket

¹ max. force 1,200 N

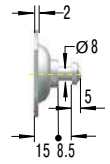

G8
Ball Socket
DIN 71805

¹ max. force 1,200 N



NG8
Angle Bracket

¹ max. force 1,000 N

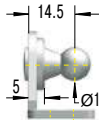

OG8
Side Bracket

¹ max. force 1,200 N

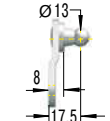

PG8
Round Bracket

¹ max. force 1,200 N

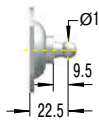

¹ Attention! Max. static load in Newtons. Beware force increase during compression (progression) and observe max. force limit.

M10x1.5 (for GS-28, GZ-28, HBD-50)

C10
Angle Ball Joint
DIN 71802

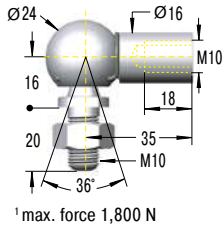

F10
Inline Ball Joint

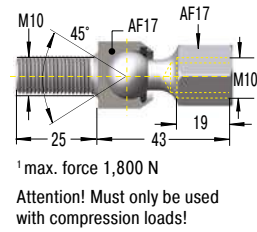

A10
Eye

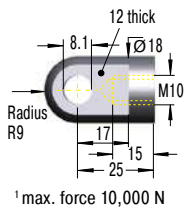

MA10
Bearing Shoe

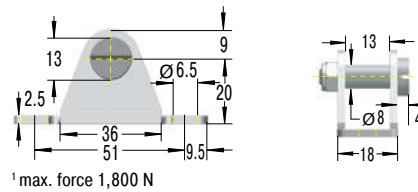

D10
Clevis Fork
DIN 71752

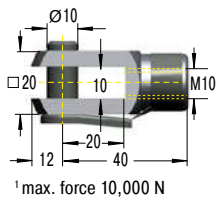

E10
Swivel Eye
DIN 648

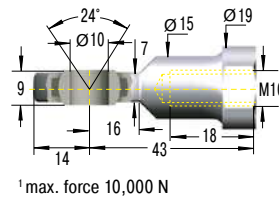

E10
Swivel Eye
DIN 648

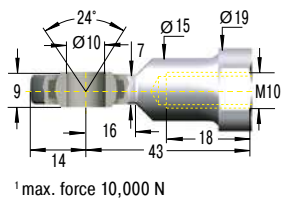

ME10
Bearing Shoe

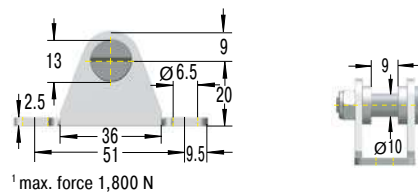

OE10
Side Bracket

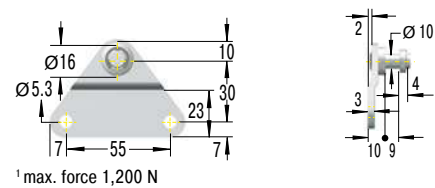

PE10
Round Bracket

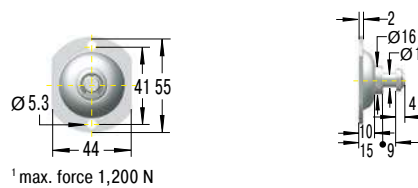

M14x1.5 (for GS-40, GST-40, GZ-40, HBD-40, HB-40)

C14
Angle Ball Joint
DIN 71802

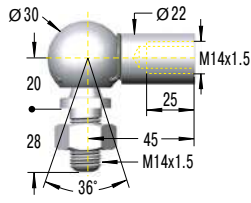

¹ max. force 3,200 N

F14
Inline Ball Joint

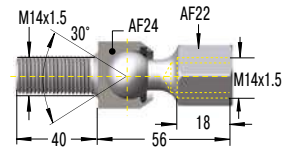

¹ max. force 3,200 N
Attention! Must only be used with compression loads!

A14
Eye

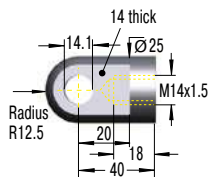

¹ max. force 10,000 N

ME14
Bearing Shoe

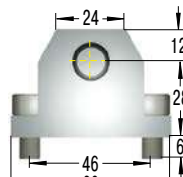

¹ max. force 10,000 N

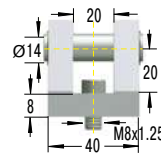

D14
Clevis Fork
DIN 71752

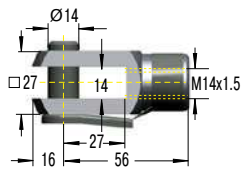

¹ max. force 10,000 N

ND14
Mounting Flange

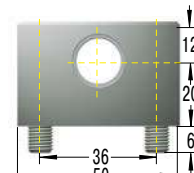

¹ max. force 10,000 N

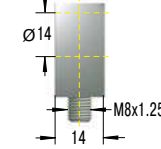

E14
Swivel Eye
DIN 648

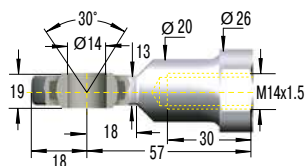

¹ max. force 10,000 N

ME14
Bearing Shoe

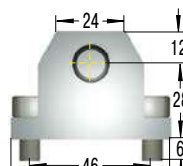

¹ max. force 10,000 N

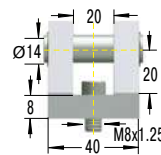

¹ Attention! Max. static load in Newtons. Beware force increase during compression (progression) and observe max. force limit.

M24x2 (for GS-70, HB-70)

D24
Clevis Fork
DIN 71752

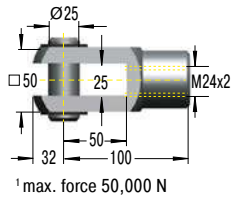

ND24
Mounting Flange

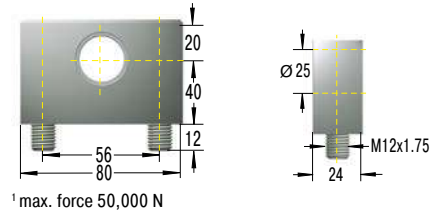

E24
Swivel Eye
DIN 648

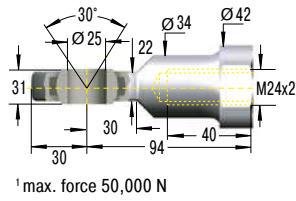

ME24
Bearing Shoe

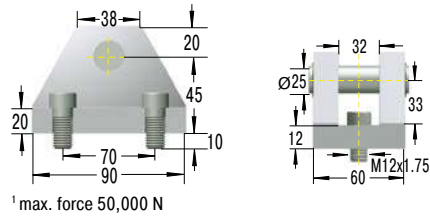

¹Attention! Max. static load in Newtons. Beware force increase during compression (progression) and observe max. force limit.

Mounting Accessories

for stainless steel gas springs and hydraulic dampers

For our gas springs and hydraulic dampers made of stainless steel we also offer a flexible product range of DIN standardized end fittings and mounting brackets. These eyes, swivel eyes, clevis forks, angle ball joints, ball sockets, inline ball joints and mounting brackets are also made of sturdy stainless steel and can be easily combined.

The high-quality stainless steel accessories are rustproof and weakly magnetic. Just as with the corresponding stainless steel gas springs and hydraulic dampers, they are preferred in the food, electronics and ship building industries along with medical and cleanroom technology.

All ACE stainless steel gas springs and the appropriate mounting accessories are individually designed for each application with the ACE calculation program.

The entire range of stainless steel accessories is also available separately.

**Infinite
Combinations!**

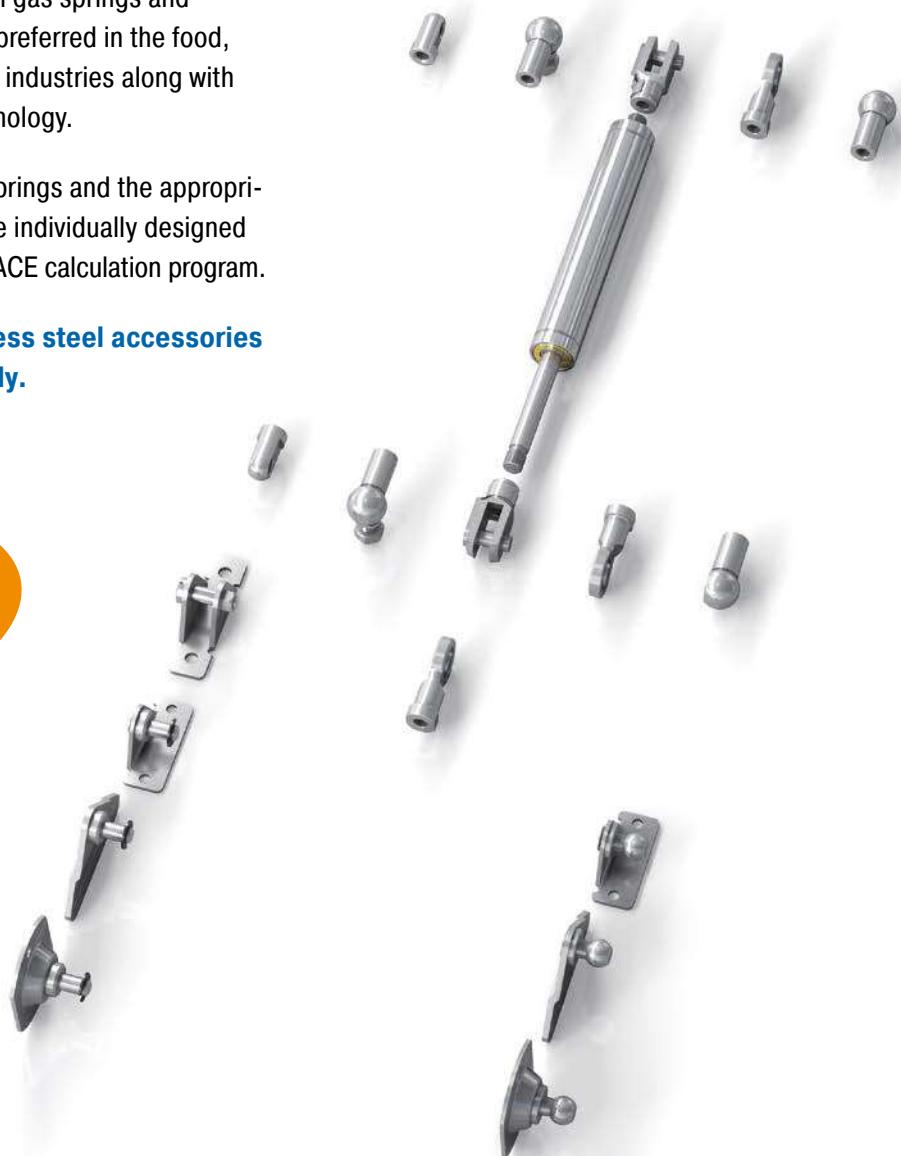

M3.5x0.6

(for GS-8-V4A, GS-10-V4A, GS-12-V4A, GZ-15-V4A)

C3.5-V4A Angle Ball Joint

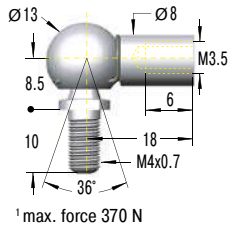

¹ max. force 370 N

A3.5-V4A Eye

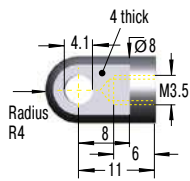

¹ max. force 370 N



NA3.5-V4A Angle Bracket

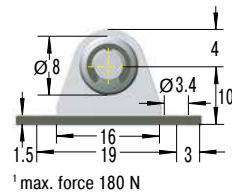

¹ max. force 180 N

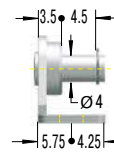

OA3.5-V4A Side Bracket

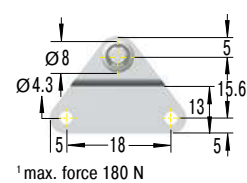

¹ max. force 180 N



D3.5-V4A Clevis Fork

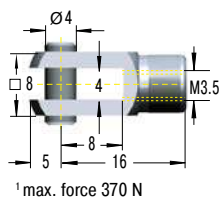

¹ max. force 370 N



A3.5-V4A Eye

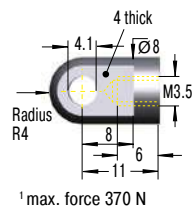

¹ max. force 370 N

G3.5-V4A Ball Socket

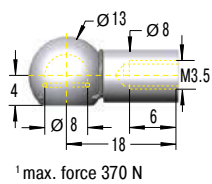

¹ max. force 370 N



NG3.5-V4A Angle Bracket

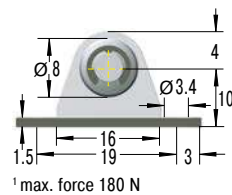

¹ max. force 180 N

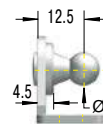

OG3.5-V4A Side Bracket

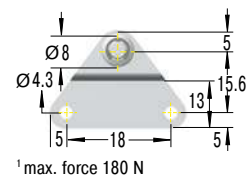

¹ max. force 180 N



¹ Attention! Max. static load in Newtons. Beware force increase during compression (progression) and observe max. force limit.

M5x0.8 (for GS-15-VA)

C5-VA
Angle Ball Joint

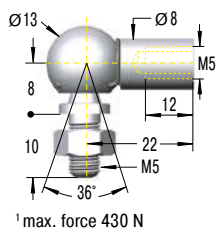

D5-VA
Clevis Fork

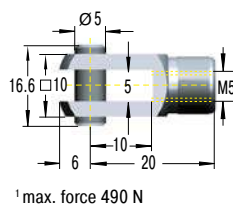

E5-VA
Swivel Eye

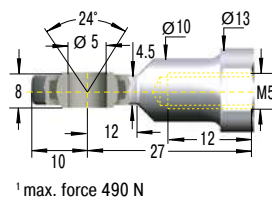

A5-VA
Eye

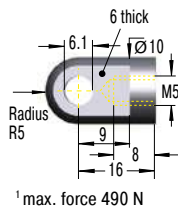

MA5-V4A
Bearing Shoe

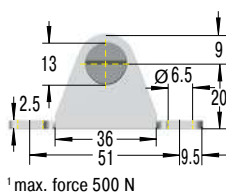

NA5-V4A
Angle Bracket

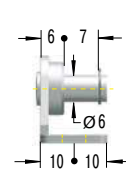
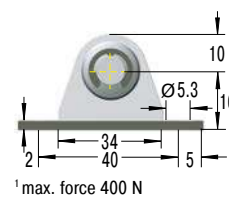

OA5-V4A
Side Bracket

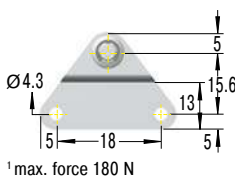

PA5-V4A
Round Bracket

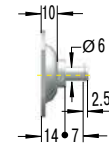
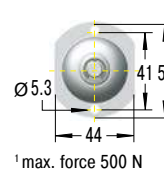

G5-VA
Ball Socket

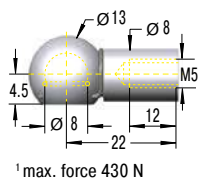

NG5-V4A
Angle Bracket

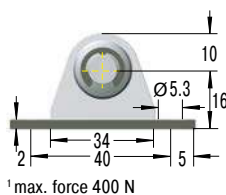

OG5-V4A
Side Bracket

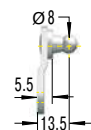
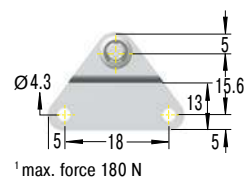

PG5-V4A
Round Bracket

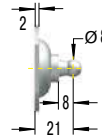
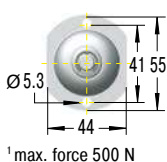

¹ Attention! Max. static load in Newtons. Beware force increase during compression (progression) and observe max. force limit.

M8x1.25 (for GS-19-VA, GS-22-VA, GZ-19-VA)

C8-VA
Angle Ball Joint

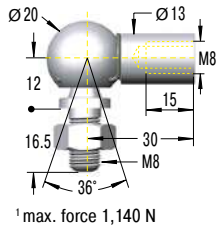

D8-VA
Clevis Fork

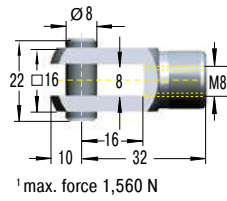

A8-VA
Eye

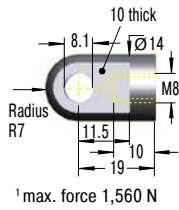

MA8-V4A
Bearing Shoe

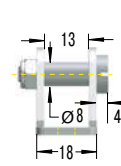
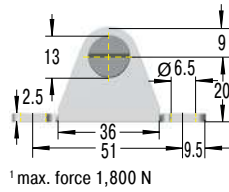

NA8-V4A
Angle Bracket

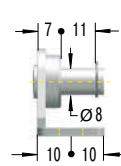
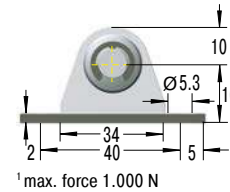

OA8-V4A
Side Bracket

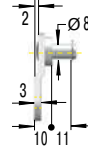
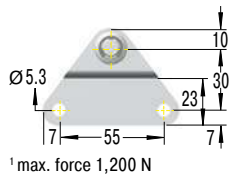

PA8-V4A
Round Bracket

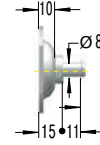
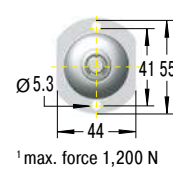

E8-VA
Swivel Eye

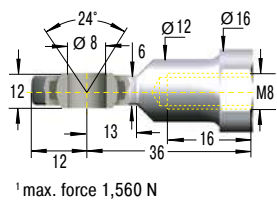

MA8-V4A
Bearing Shoe

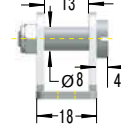
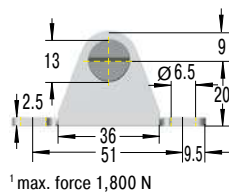

¹Attention! Max. static load in Newtons. Beware force increase during compression (progression) and observe max. force limit.

M8x1.25 (for GS-19-VA, GS-22-VA, GZ-19-VA)

G8-VA
Ball Socket

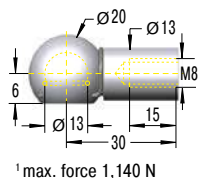

NG8-V4A
Angle Bracket

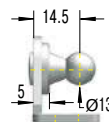
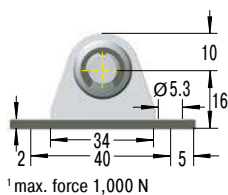

OG8-V4A
Side Bracket

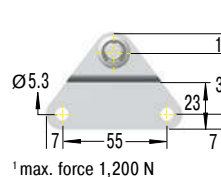

PG8-V4A
Round Bracket

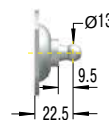
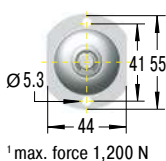

M10x1.5 (for GS-28-VA, GZ-28-VA)

C10-VA
Angle Ball Joint

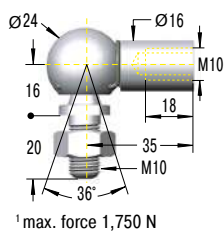

D10-VA
Clevis Fork

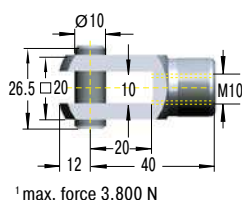

E10-VA
Swivel Eye

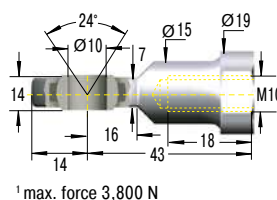

A10-VA
Eye

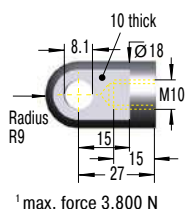

MA10-V4A
Bearing Shoe

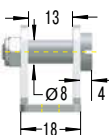
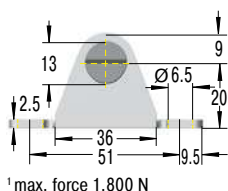

¹ Attention! Max. static load in Newtons. Beware force increase during compression (progression) and observe max. force limit.

M14x1.5 (for GS-40-VA, GZ-40-VA)

C14-VA Angle Ball Joint

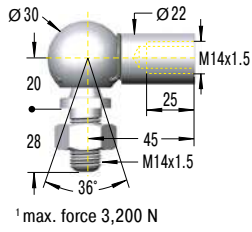

¹ max. force 3,200 N

A14-VA Eye

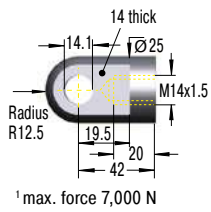

¹ max. force 7,000 N

ME14-VA Bearing Shoe

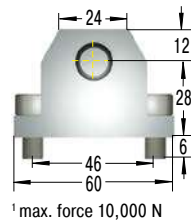

¹ max. force 10,000 N

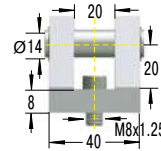

D14-VA Clevis Fork

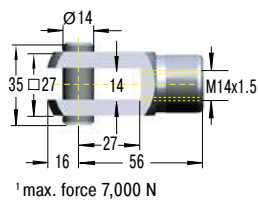

¹ max. force 7,000 N

ND14-VA Mounting Flange

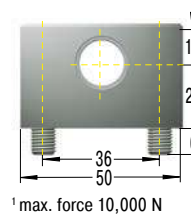

¹ max. force 10,000 N



E14-VA Swivel Eye

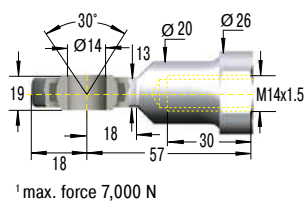

¹ max. force 7,000 N

ME14-VA Bearing Shoe

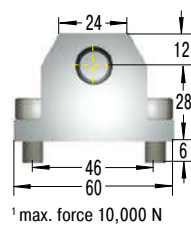

¹ max. force 10,000 N

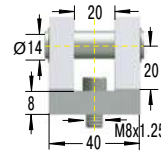

¹ Attention! Max. static load in Newtons. Beware force increase during compression (progression) and observe max. force limit.