

# Alfa Laval T2

## Gasketed plate heat exchanger for a wide range of applications

### Introduction

Alfa Laval Industrial line is a wide product range that is used in virtually all types of industry.

Suitable for a wide range of applications, this is the smallest model in the industrial range of gasketed plate-and-frame heat exchangers.

### Applications

- Biotech and Pharmaceutical
- Chemicals
- Energy and Utilities
- Food, Dairy and Beverages
- Home and Personal care
- HVAC and Refrigeration
- Machinery and Manufacturing
- Marine and Transportation
- Mining, Minerals and Pigments
- Pulp and Paper
- Semiconductor and Electronics
- Steel
- Water and Waste treatment

### Benefits

- High energy efficiency – low operating cost
- Flexible configuration – heat transfer area can be modified
- Easy to install – compact design
- High serviceability – easy to open for inspection and cleaning and easy to clean by CIP
- Access to Alfa Laval's global service network

### Features

Every detail is carefully designed to ensure optimal performance, maximum uptime and easy maintenance. Selection of available features, depending on configuration some features may not be applicable:

- Clip-on gasket
- Leak chamber
- Lining

### Alfa Laval 360° Service Portfolio

Our extensive service offering ensure top performance from your Alfa Laval equipment throughout its life cycle. The Alfa Laval 360 Service Portfolio include installation services, cleaning and repair as well as spare parts, technical



documentation and trouble shooting. We also offer replacement, retrofit, integrity testing, monitoring and much more.

For information about our complete service offering and how to contact us - please visit [www.alfalaval.com/service](http://www.alfalaval.com/service).

## Dimensional drawing

Measurements mm (inches)

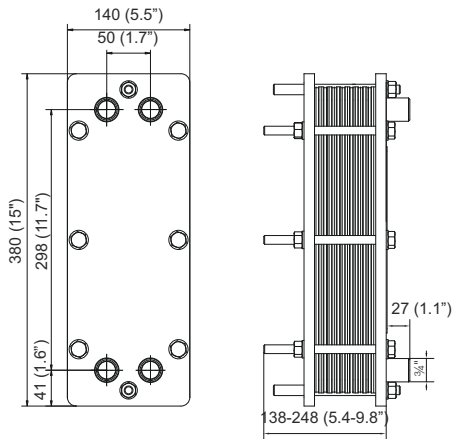

## Technical data

Plates	Type	Free channel, mm (inches)
B	Single plate	2.4 (0.095)

### Materials

Heat transfer plates	316/316L Ti
Field gaskets	NBR, EPDM
Pipe connections	Stainless steel, titanium
Frame and pressure plate	Carbon steel, epoxy painted

Other materials may be available on request.

## Operational data

Frame type	Max. design pressure barg (psig)	Max. design temperature °C (°F)
FG, pvcALS	16.0 (232)	180 (356)

Extended pressure and temperature rating may be available on request.

## General remarks for technical information

- The global offering presented in this leaflet may not be available for all regions
- All combinations may not be configurable

## Pipe connections

Connection type	Connection standard
External tapered threaded	ISO 7 - R 3/4

Other connection types may be available on request.

This document and its contents are subject to copyrights and other intellectual property rights owned by Alfa Laval AB (publ) or any of its affiliates (jointly "Alfa Laval"). No part of this document may be copied, re-produced or transmitted in any form or by any means, or for any purpose, without Alfa Laval's prior express written permission. Information and services provided in this document are made as a benefit and service to the user, and no representations or warranties are made about the accuracy or suitability of this information and these services for any purpose. All rights are reserved.

## How to contact Alfa Laval

Up-to-date Alfa Laval contact details for all countries are always available on our website at [www.alfalaval.com](http://www.alfalaval.com)

# Alfa Laval T5

## Gasketed plate heat exchanger for a wide range of applications

### Introduction

Alfa Laval Industrial line is a wide product range that is used in virtually all types of industry.

Suitable for a wide range of applications, this model is available with a large selection of plate and gasket types.

### Applications

- Biotech and Pharmaceutical
- Chemicals
- Energy and Utilities
- Food, Dairy and Beverages
- Home and Personal care
- HVAC and Refrigeration
- Machinery and Manufacturing
- Marine and Transportation
- Mining, Minerals and Pigments
- Pulp and Paper
- Semiconductor and Electronics
- Steel
- Water and Waste treatment

### Benefits

- High energy efficiency – low operating cost
- Flexible configuration – heat transfer area can be modified
- Easy to install – compact design
- High serviceability – easy to open for inspection and cleaning and easy to clean by CIP
- Access to Alfa Laval's global service network

### Features

Every detail is carefully designed to ensure optimal performance, maximum uptime and easy maintenance. Selection of available features, depending on configuration some features may not be applicable:



- Corner guided alignment system
- Clip-on gasket
- Offset gasket groove
- Leak chamber
- Fixed bolt head
- Key hole bolt opening
- Lifting lug
- Lining



- Lock washer
- Tightening bolt cover

### Alfa Laval 360° Service Portfolio

Our extensive service offering ensure top performance from your Alfa Laval equipment throughout its life cycle. The Alfa Laval 360 Service Portfolio include installation services, cleaning and repair as well as spare parts, technical documentation and trouble shooting. We also offer replacement, retrofit, integrity testing, monitoring and much more.

For information about our complete service offering and how to contact us - please visit [www.alfalaval.com/service](http://www.alfalaval.com/service).

## Dimensional drawing

Measurements mm (inches)

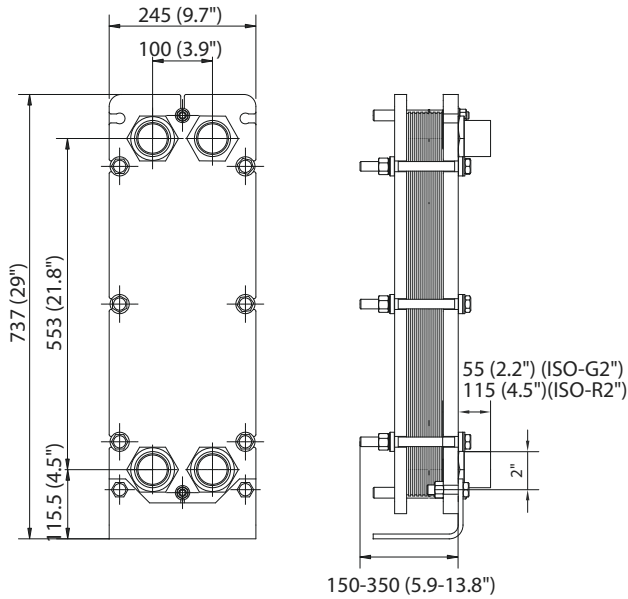

## Flange connections

Frame type	Connection standard
FG, pvcALS	ASME B16.5 Class 150 NPS 1 1/2

## Pipe connections

Connection type	Connection standard
Threaded port	ISO 228 - G 2
External parallel threaded	ISO 228 - G 2 B
External tapered threaded	ISO 7 - R 2 2 - 11.5 NPT

Other connection types may be available on request.

## Technical data

Plates	Type	Free channel, mm (inches)
B	Single plate	1.8 (0.07)
M	Single plate	2.9 (0.11)

## Materials

Heat transfer plates	304/304L, 316/316L Ti
Field gaskets	NBR, EPDM
Flange connections	Rubber lined: NBR
Pipe connections	Stainless steel, titanium
Frame and pressure plate	Carbon steel, epoxy painted

Other materials may be available on request.

## Operational data

Frame type	Max. design pressure barg (psig)	Max. design temperature °C (°F)
FG, pvcALS	16.0 (232)	180 (356)
FG, ASME	10.3 (150)	180 (356)
FG, PED	16.0 (232)	160 (320)

Extended pressure and temperature rating may be available on request.

## General remarks for technical information

- The global offering presented in this leaflet may not be available for all regions
- All combinations may not be configurable

This document and its contents are subject to copyrights and other intellectual property rights owned by Alfa Laval AB (publ) or any of its affiliates (jointly "Alfa Laval"). No part of this document may be copied, re-produced or transmitted in any form or by any means, or for any purpose, without Alfa Laval's prior express written permission. Information and services provided in this document are made as a benefit and service to the user, and no representations or warranties are made about the accuracy or suitability of this information and these services for any purpose. All rights are reserved.

## How to contact Alfa Laval

Up-to-date Alfa Laval contact details for all countries are always available on our website at [www.alfalaval.com](http://www.alfalaval.com)

# Alfa Laval T6

## Gasketed plate heat exchanger for a wide range of applications

### Introduction

Alfa Laval Industrial line is a wide product range that is used in virtually all types of industry.

Designed for high throughput, this model delivers excellent thermal performance. A large selection of plate and gasket types is available.

### Applications

- Biotech and Pharmaceutical
- Chemicals
- Energy and Utilities
- Food, Dairy and Beverages
- Home and Personal care
- HVAC and Refrigeration
- Machinery and Manufacturing
- Marine and Transportation
- Mining, Minerals and Pigments
- Pulp and Paper
- Semiconductor and Electronics
- Steel
- Water and Waste treatment

### Benefits

- High energy efficiency – low operating cost
- Flexible configuration – heat transfer area can be modified
- Easy to install – compact design
- High serviceability – easy to open for inspection and cleaning and easy to clean by CIP
- Access to Alfa Laval's global service network

### Features

Every detail is carefully designed to ensure optimal performance, maximum uptime and easy maintenance. Selection of available features, depending on configuration some features may not be applicable:



- CurveFlow™ distribution area
- ClipGrip™ gasket attachment
- Offset gasket groove
- OmegaPort™ noncircular port holes
- Leak chamber
- SteerLock™ plate alignment
- FlexFlow™ plate design



- Compact frame
- Fixed bolt head
- Key hole bolt opening
- Lifting lug
- Lining
- Lock washer
- Tightening bolt cover

### Alfa Laval 360° Service Portfolio

Our extensive service offering ensure top performance from your Alfa Laval equipment throughout its life cycle. The Alfa Laval 360 Service Portfolio include installation services, cleaning and repair as well as spare parts, technical documentation and trouble shooting. We also offer replacement, retrofit, integrity testing, monitoring and much more.

For information about our complete service offering and how to contact us - please visit [www.alfalaval.com/service](http://www.alfalaval.com/service).

## Dimensional drawing

Measurements mm (inches)

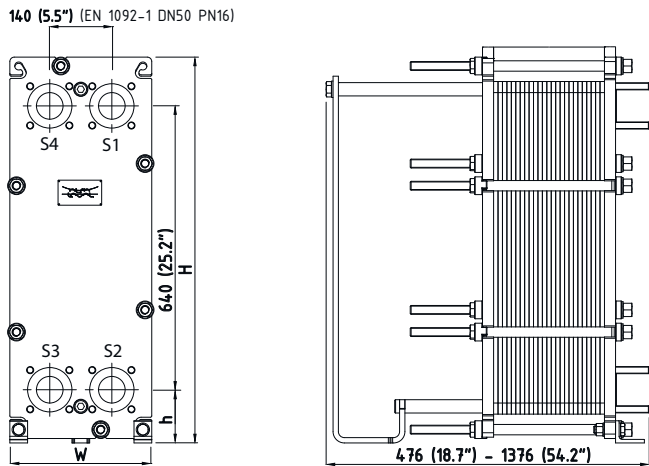

Frame type	H	W	h
FM ALS	890 (35")	320 (12.6")	140 (5.51")
FG ALS, PED, ASME, Marine <sup>1</sup>	890 (35")	320 (12.6")	140 (5.51")
FD ALS, PED, ASME	890 (35")	330 (13")	130 (5.12")

<sup>1</sup> Marine includes the pressure vessel codes: ABS, BV, CCS, ClassNK, DNV, KR, LR, RINA, and RMRS.

The number of tightening bolts may vary depending on pressure rating.

## Technical data

Plates	Type	Free channel, mm (inches)
B	Single plate	1.80 (0.07)
P	Single plate	3.00 (0.12)
Mc	Single plate	3.00 (0.12)
MDC	Double wall plate	3.00 (0.12)

## Materials

Heat transfer plates	304, 316, 254, C276, C2000, D205, Ni, Ti, TiPd, G30
Field gaskets	NBR, EPDM, FKM, HNBR, HeatSeal
Flange connections	Metal lined: stainless steel, titanium
Frame and pressure plate	Carbon steel, epoxy painted

Other materials may be available on request.

## Operational data

Frame type	Max. design pressure barg (psig)	Max. design temperature °C (°F)
FM, pvcALS	12.0 (174)	200 (392)
FG, pvcALS	18.0 (261)	200 (392)
FG, ASME	11.2 (162)	250 (482)
FG, PED	20.0 (290)	200 (392)

<sup>1</sup> Marine includes the standards: ABS, BV, CCS, ClassNK, DNV, KR, LR, RINA, and RMRS.

Frame type	Max. design pressure barg (psig)	Max. design temperature °C (°F)
FG, Marine <sup>1</sup>	18.0 (261)	180 (356)
FD, pvcALS	31.0 (449.5)	200 (392)
FD, ASME	23.8 (345)	250 (482)
FD, PED	31.0 (449.5)	200 (392)

<sup>1</sup> Marine includes the standards: ABS, BV, CCS, ClassNK, DNV, KR, LR, RINA, and RMRS.

Extended pressure and temperature rating may be available on request.

## General remarks for technical information

- The global offering presented in this leaflet may not be available for all regions
- All combinations may not be configurable

## Flange connections

Frame type	Connection standard
FM, pvcALS	EN 1092-1 DN50 PN10
	ASME B16.5 Class 150 NPS 2 JIS B2220 10K 50A
FG, pvcALS	EN 1092-1 DN50 PN16
	ASME B16.5 Class 150 NPS 2 JIS B2220 10K 50A
	JIS B2220 16K 50A
FG, Marine <sup>1</sup>	EN 1092-1 DN50 PN16
	ASME B16.5 Class 150 NPS 2 JIS B2220 10K 50A
	JIS B2220 16K 50A
FG, ASME	ASME B16.5 Class 150 NPS 2
	EN 1092-1 DN50 PN16
FG, PED	EN 1092-1 DN50 PN16
	ASME B16.5 Class 150 NPS 2
FD, pvcALS	EN 1092-1 DN50 PN25
	ASME B16.5 Class 150 NPS 4
	ASME B16.5 Class 300 NPS 2 (Rectangular Loose Flange) JIS B2220 20K 50A (Rectangular Loose Flange)
FD, ASME	ASME B16.5 Class 300 NPS 2 (Rectangular Loose Flange)
FD, PED	EN 1092-1 DN50 PN25
	ASME B16.5 Class 300 NPS 2 (Rectangular Loose Flange)

<sup>1</sup> Marine includes the standards: ABS, BV, CCS, DNV, ClassNK, KR, LR, RINA, and RMRS.

## Pipe connections

Connection type	Connection standard
Threaded port	ISO 228 - G 2
Straight welded	NPS 2 (80 mm)
External thread	ISO 228 - G 2 B
	2 - 11.5 NPT

Other connection types may be available on request.

This document and its contents are subject to copyrights and other intellectual property rights owned by Alfa Laval AB (publ) or any of its affiliates (jointly "Alfa Laval"). No part of this document may be copied, re-produced or transmitted in any form or by any means, or for any purpose, without Alfa Laval's prior express written permission. Information and services provided in this document are made as a benefit and service to the user, and no representations or warranties are made about the accuracy or suitability of this information and these services for any purpose. All rights are reserved.

## How to contact Alfa Laval

Up-to-date Alfa Laval contact details for all countries are always available on our website at [www.alfalaval.com](http://www.alfalaval.com)

# Alfa Laval T8

## Gasketed plate heat exchanger for a wide range of applications

### Introduction

Alfa Laval Industrial line is a wide product range that is used in virtually all types of industry.

Suitable for a wide range of applications, this model is available with a large selection of plate and gasket types.

### Applications

- Biotech and Pharmaceutical
- Chemicals
- Energy and Utilities
- Food, Dairy and Beverages
- HVAC and Refrigeration
- Machinery and Manufacturing
- Marine and Transportation
- Mining, Minerals and Pigments
- Pulp and Paper
- Semiconductor and Electronics
- Steel

### Benefits

- High energy efficiency – low operating cost
- Flexible configuration – heat transfer area can be modified
- Easy to install – compact design
- High serviceability – easy to open for inspection and cleaning and easy to clean by CIP
- Access to Alfa Laval's global service network

### Features

Every detail is carefully designed to ensure optimal performance, maximum uptime and easy maintenance. Selection of available features, depending on configuration some features may not be applicable:



- Corner guided alignment system
- CurveFlow™ distribution area
- ClipGrip™ gasket attachment
- Offset gasket groove
- OmegaPort™ noncircular port holes
- Leak chamber
- Fixed bolt head
- Key hole bolt opening
- Lifting lug
- Lining

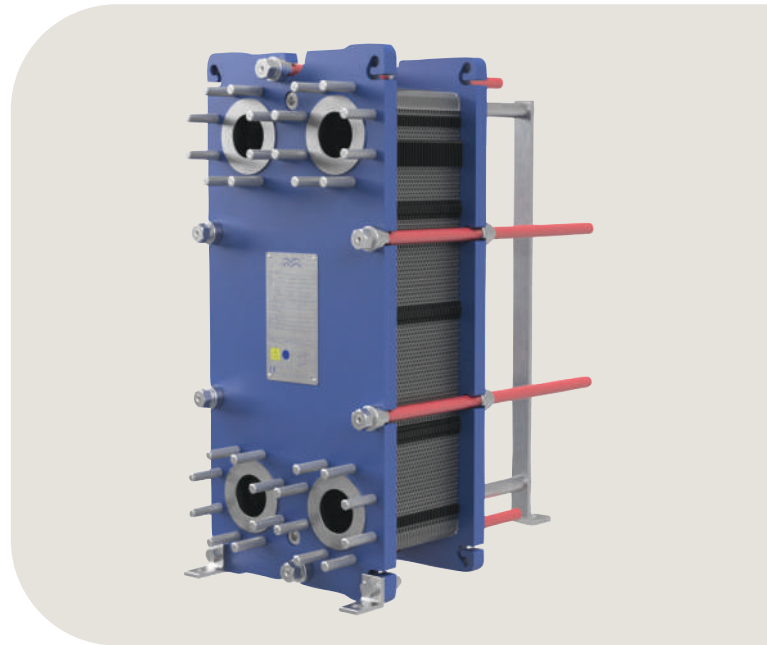

- Lock washer
- Tightening bolt cover

### Alfa Laval 360° Service Portfolio

Our extensive service offering ensure top performance from your Alfa Laval equipment throughout its life cycle. The Alfa Laval 360 Service Portfolio include installation services, cleaning and repair as well as spare parts, technical documentation and trouble shooting. We also offer replacement, retrofit, integrity testing, monitoring and much more.

For information about our complete service offering and how to contact us - please visit [www.alfalaval.com/service](http://www.alfalaval.com/service).

## Dimensional drawing

Measurements mm (inches)

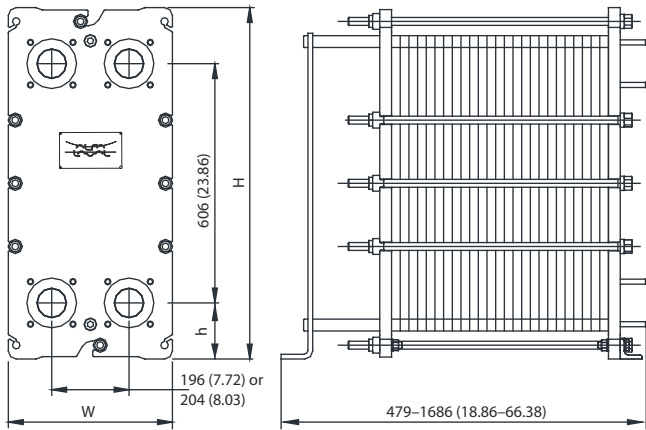

Frame type	H	W	h
FM	890 (35.04")	400 (15.78")	142 (5.59")
FG	890 (35.04")	400 (15.78")	142 (5.59")
FG, ASME	890 (35.04")	416 (16.38")	142 (5.59")

The number of tightening bolts may vary depending on pressure rating.

## Technical data

Plates	Type	Free channel, mm (inches)
B	Single plate	2.3 (0.091)
M	Single plate	3.9 (0.15)

### Materials

Heat transfer plates	304/304L, 316/316L Ti
Field gaskets	NBR, EPDM
Flange connections	Metal lined: stainless steel, titanium Rubber lined: NBR
Frame and pressure plate	Carbon steel, epoxy painted

Other materials may be available on request.

## Operational data

Frame type	Max. design pressure barg (psig)	Max. design temperature °C (°F)
FM, PED	13.0 (188)	180 (356)
FM, pvcALS	13.5 (196)	180 (356)
FG, pvcALS	15.5 (225)	180 (356)
FG, ASME	10.3 (150)	250 (482)
FG, PED	17.5 (253)	180 (356)

Extended pressure and temperature rating may be available on request.

## General remarks for technical information

- The global offering presented in this leaflet may not be available for all regions
- All combinations may not be configurable

## Flange connections

Frame type	Connection standard
FM, pvcALS	EN 1092-1 DN80 PN10
	ASME B16.5 Class 150 NPS 3
	JIS B2220 10K 80A
FM, PED	EN 1092-1 DN80 PN10
	ASME B16.5 Class 150 NPS 3
FG, pvcALS	EN 1092-1 DN80 PN16
	ASME B16.5 Class 150 NPS 3
	JIS B2220 10K 80A
	JIS B2220 16K 80A
FG, ASME	ASME B16.5 Class 150 NPS 3
	EN 1092-1 DN80 PN16
FG, PED	EN 1092-1 DN80 PN16
	ASME B16.5 Class 150 NPS 3

Standard EN1092-1 corresponds to GOST 12815-80 and GB/T9124.1.

This document and its contents are subject to copyrights and other intellectual property rights owned by Alfa Laval AB (publ) or any of its affiliates (jointly "Alfa Laval"). No part of this document may be copied, re-produced or transmitted in any form or by any means, or for any purpose, without Alfa Laval's prior express written permission. Information and services provided in this document are made as a benefit and service to the user, and no representations or warranties are made about the accuracy or suitability of this information and these services for any purpose. All rights are reserved.

## How to contact Alfa Laval

Up-to-date Alfa Laval contact details for all countries are always available on our website at [www.alfalaval.com](http://www.alfalaval.com)

# Alfa Laval T10

## Gasketed plate heat exchanger for a wide range of applications

### Introduction

Alfa Laval Industrial line is a wide product range that is used in virtually all types of industry.

Designed for high throughput, this model delivers excellent thermal performance. A large selection of plate and gasket types is available.

### Applications

- Biotech and Pharmaceutical
- Chemicals
- Energy and Utilities
- Food, Dairy and Beverages
- Home and Personal care
- HVAC and Refrigeration
- Machinery and Manufacturing
- Marine and Transportation
- Mining, Minerals and Pigments
- Pulp and Paper
- Semiconductor and Electronics
- Steel
- Water and Waste treatment

### Benefits

- High energy efficiency – low operating cost
- Flexible configuration – heat transfer area can be modified
- Easy to install – compact design
- High serviceability – easy to open for inspection and cleaning and easy to clean by CIP
- Access to Alfa Laval's global service network

### Features

Every detail is carefully designed to ensure optimal performance, maximum uptime and easy maintenance. Selection of available features, depending on configuration some features may not be applicable:



- CurveFlow™ distribution area
- ClipGrip™ gasket attachment
- Offset gasket groove
- OmegaPort™ noncircular port holes
- Leak chamber
- SteerLock™ plate alignment
- FlexFlow™ plate design



- Compact frame
- Fixed bolt head
- Key hole bolt opening
- Lifting lug
- Lining
- Lock washer
- Tightening bolt cover

### Alfa Laval 360° Service Portfolio

Our extensive service offering ensure top performance from your Alfa Laval equipment throughout its life cycle. The Alfa Laval 360 Service Portfolio include installation services, cleaning and repair as well as spare parts, technical documentation and trouble shooting. We also offer replacement, retrofit, integrity testing, monitoring and much more.

For information about our complete service offering and how to contact us - please visit [www.alfalaval.com/service](http://www.alfalaval.com/service).

## Dimensional drawing

Measurements mm (inches)

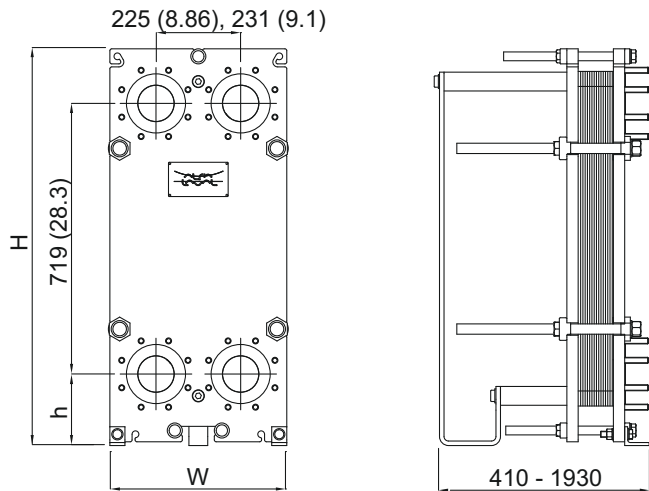

Frame type	H	W	h
FM ALS, PED	1054 (41.5")	470 (18.5")	190 (7.48")
FG ALS, PED, Marine <sup>1</sup>	1054 (41.5")	470 (18.5")	190 (7.48")
FG ASME	1054 (41.5")	470 (18.5")	190 (7.48")
FD ALS, PED	1054 (41.5")	470 (18.5")	190 (7.48")
FD ASME	1054 (41.5")	470 (18.5")	190 (7.48")

<sup>1</sup> Marine includes the pressure vessel codes: ABS, BV, CCS, ClassNK, DNV, KR, LR, RINA, and RMRS.

The number of tightening bolts may vary depending on pressure rating.

## Technical data

Plates	Type	Free channel, mm (inches)
Bc	Single plate	2.55 (0.10)
B	Single plate	2.52 (0.099)
M	Single plate	3.95 (0.155)
BDC	Double wall plate	2.6 (0.10)
Mc	Single plate	3.95 (0.155)

## Materials

Heat transfer plates	304, 316/316L, C276, D205, C2000, Ni, Ti, TiPd
Field gaskets	NBR, EPDM, FKM, HNBR, HeatSeal
Flange connections	Metal lined: stainless steel, Alloy 254, titanium, Alloy C276, Nickel 200/201, TiPd11
Frame and pressure plate	Carbon steel, epoxy painted

Other materials may be available on request.

## Operational data

Frame type	Max. design pressure barg (psig)	Max. design temperature °C (°F)
FM, PED	10.0 (145)	180 (356)
FM, pvcALS	10.0 (145)	180 (356)
FG, pvcALS	15.0 (218)	150 (302)
FG, ASME	10.4 (151)	250 (482)
FG, PED	15.0 (218)	150 (302)
FG, Marine <sup>1</sup>	15.0 (218)	200 (392)
FD, pvcALS	25.0 (362)	200 (392)
FD, ASME	21.0 (304)	250 (482)
FD, PED	25.0 (362)	200 (392)

<sup>1</sup> Marine includes the standards: ABS, BV, CCS, ClassNK, DNV, KR, LR, RINA, and RMRS.

Extended pressure and temperature rating may be available on request.

## General remarks for technical information

- The global offering presented in this leaflet may not be available for all regions
- All combinations may not be configurable

## Flange connections

Frame type	Connection standard
FM, pvcALS	EN 1092-1 DN100 PN10
	ASME B16.5 Class 150 NPS 4
	JIS B2220 10K 100A
FM, PED	EN 1092-1 DN100 PN10
	ASME B16.5 Class 150 NPS 4
FG, pvcALS	EN 1092-1 DN100 PN16
	ASME B16.5 Class 150 NPS 4
	JIS B2220 10K 100A
	JIS B2220 16K 100A
FG, Marine <sup>1</sup>	EN 1092-1 DN100 PN16
	ASME B16.5 Class 150 NPS 4
	JIS B2220 10K 100A
	JIS B2220 16K 100A
FG, ASME	ASME B16.5 Class 150 NPS 4
	EN 1092-1 DN100 PN16
FG, PED	EN 1092-1 DN100 PN16
	ASME B16.5 Class 150 NPS 4
FD, pvcALS	EN 1092-1 DN100 PN25
	ASME B16.5 Class 150 NPS 4
	JIS B2220 16K 100A
FD, ASME	ASME B16.5 Class 150 NPS 4
	ASME B16.5 Class 300 NPS 4 (Rectangular Loose Flange)
FD, PED	EN 1092-1 DN100 PN25
	ASME B16.5 Class 150 NPS 4

<sup>1</sup> Marine includes the standards: ABS, BV, CCS, DNV, ClassNK, KR, LR, RINA, and RMRS.

Standard EN1092-1 corresponds to GOST 12815-80 and GB/T9124.1.

This document and its contents are subject to copyrights and other intellectual property rights owned by Alfa Laval AB (publ) or any of its affiliates (jointly "Alfa Laval"). No part of this document may be copied, re-produced or transmitted in any form or by any means, or for any purpose, without Alfa Laval's prior express written permission. Information and services provided in this document are made as a benefit and service to the user, and no representations or warranties are made about the accuracy or suitability of this information and these services for any purpose. All rights are reserved.

## How to contact Alfa Laval

Up-to-date Alfa Laval contact details for all countries are always available on our website at [www.alfalaval.com](http://www.alfalaval.com)

# Alfa Laval T15

## Gasketed plate heat exchanger for a wide range of applications

### Introduction

Alfa Laval Industrial line is a wide product range that is used in virtually all types of industry.

Suitable for a wide range of applications, this model is available with a large selection of plate and gasket types.

### Applications

- Biotech and Pharmaceutical
- Chemicals
- Energy and Utilities
- Food, Dairy and Beverages
- Home and Personal care
- HVAC and Refrigeration
- Machinery and Manufacturing
- Marine and Transportation
- Mining, Minerals and Pigments
- Pulp and Paper
- Semiconductor and Electronics
- Steel
- Water and Waste treatment

### Benefits

- High energy efficiency – low operating cost
- Flexible configuration – heat transfer area can be modified
- Easy to install – compact design
- High serviceability – easy to open for inspection and cleaning and easy to clean by CIP
- Access to Alfa Laval's global service network

### Features

Every detail is carefully designed to ensure optimal performance, maximum uptime and easy maintenance. Selection of available features, depending on configuration some features may not be applicable:



- Five-point alignment
- T-bar roller
- CurveFlow™ distribution area
- ClipGrip™ gasket attachment
- Offset gasket groove
- OmegaPort™ noncircular port holes
- Leak chamber
- SteerLock™ plate alignment



- FlexFlow™ plate design
- Compact frame
- Bearing boxes
- Fixed bolt head
- Key hole bolt opening
- Lifting lug
- Lining
- Lock washer
- Tightening bolt cover

### Alfa Laval 360° Service Portfolio

Our extensive service offering ensure top performance from your Alfa Laval equipment throughout its life cycle. The Alfa Laval 360 Service Portfolio include installation services, cleaning and repair as well as spare parts, technical documentation and trouble shooting. We also offer replacement, retrofit, integrity testing, monitoring and much more.

For information about our complete service offering and how to contact us - please visit [www.alfalaval.com/service](http://www.alfalaval.com/service).

## Dimensional drawing

Measurements mm (inches)

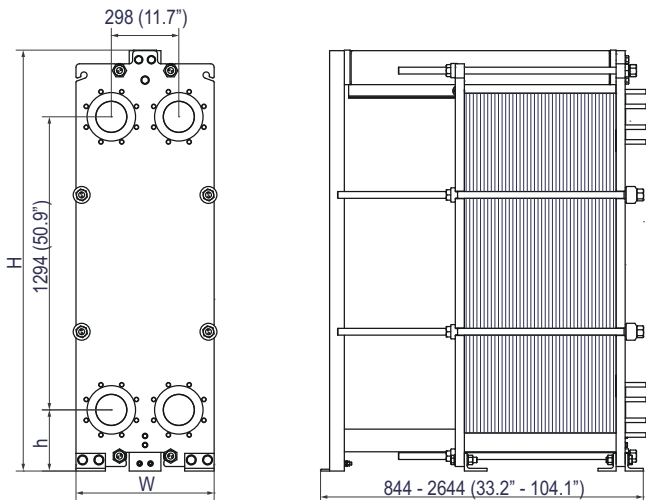

Frame type	H	W	h
FM, PED, ALS, Marine <sup>1</sup>	1833 (72.7")	610 (24.0")	270 (10.6")
FG, PED, ALS, Marine <sup>1</sup>	1871 (73.7")	650 (25.6")	284.5 (11.2")
FG, ASME	1856 (73.1")	650 (25.6")	270 (10.6")
FS, PED, ALS, ASME	1871 (73.7")	650 (25.6")	284.5 (11.2")
FD, ASME	1871 (73.7")	650 (25.6")	284.5 (11.2")

<sup>1</sup> Marine includes the pressure vessel codes: ABS, BV, CCS, ClassNK, DNV, KR, LR, RINA, and RMRS.

The number of tightening bolts may vary depending on pressure rating.

## Technical data

Plates	Type	Free channel, mm (inches)
B	Single plate	2.42 (0.0953)
M	Single plate	3.80 (0.1496)
BDC	Double wall plate	2.45 (0.0965)

## Materials

Heat transfer plates	304, 316, 254, C276, Ni, C2000, G30, D205, Ti, TiPd
Field gaskets	NBR, EPDM, FKM, HNBR, HeatSeal
Flange connections	Metal lined: stainless steel, Alloy 254, Alloy C276, titanium Rubber lined: NBR, EPDM
Frame and pressure plate	Carbon steel, epoxy painted

Other materials may be available on request.

## Operational data

Frame type	Max. design pressure barg (psig)	Max. design temperature °C (°F)
FM, PED	10.4 (151)	200 (392)
FM, pvcALS	10.4 (151)	200 (392)
FM, Marine <sup>1</sup>	10.4 (151)	180 (356)
FG, pvcALS	16.0 (232)	200 (392)
FG, ASME	11.0 (159)	250 (482)
FG, PED	16.0 (232)	200 (392)
FG, Marine <sup>1</sup>	16.0 (232)	180 (356)
FD, ASME	21.0 (304)	250 (482)

<sup>1</sup> Marine includes the standards: ABS, BV, CCS, ClassNK, DNV, KR, LR, RINA, and RMRS.

Frame type	Max. design pressure barg (psig)	Max. design temperature °C (°F)
FS, pvcALS	38.0 (551)	200 (392)
FS, ASME	36.0 (522)	250 (482)
FS, PED	38.0 (551)	200 (392)

<sup>1</sup> Marine includes the standards: ABS, BV, CCS, ClassNK, DNV, KR, LR, RINA, and RMRS.

Extended pressure and temperature rating may be available on request.

## General remarks for technical information

- The global offering presented in this leaflet may not be available for all regions
- All combinations may not be configurable

## Flange connections

Frame type	Connection standard
FM, pvcALS	EN 1092-1 DN150 PN10
	EN 1092-1 DN150 PN16
	ASME B16.5 Class 150 NPS 6 JIS B2220 10K 150A
FM, PED	EN 1092-1 DN150 PN10
	EN 1092-1 DN150 PN16
	ASME B16.5 Class 150 NPS 6
FM, Marine <sup>1</sup>	EN 1092-1 DN250 PN10
	EN 1092-1 DN150 PN16
	ASME B16.5 Class 150 NPS 6 JIS B2220 10K 150A
FG, pvcALS	EN 1092-1 DN150 PN16
	EN 1092-1 DN150 PN25
	ASME B16.5 Class 150 NPS 6 JIS B2220 10K 150A JIS B2220 16K 150A
FG, Marine <sup>1</sup>	EN 1092-1 DN150 PN16
	ASME B16.5 Class 150 NPS 6
	JIS B2220 10K 150A JIS B2220 16K 150A
FG, ASME	ASME B16.5 Class 150 NPS 6
FG, PED	EN 1092-1 DN150 PN16
	EN 1092-1 DN150 PN25 ASME B16.5 Class 150 NPS 6
FD, ASME	ASME B16.5 Class 150 NPS 6
	ASME B16.5 Class 300 NPS 6
FS, pvcALS	EN 1092-1 DN150 PN25
	EN 1092-1 DN150 PN40
	ASME B16.5 Class 300 NPS 6 JIS B2220 20K 150A
FS, ASME	ASME B16.5 Class 300 NPS 6
FS, PED	EN 1092-1 DN150 PN25
	EN 1092-1 DN150 PN40 ASME B16.5 Class 300 NPS 6

<sup>1</sup> Marine includes the standards: ABS, BV, CCS, DNV, ClassNK, KR, LR, RINA, and RMRS.

Standard EN1092-1 corresponds to GOST 12815-80 and GB/T9124.1.

# Alfa Laval T21

## Gasketed plate heat exchanger for a wide range of applications

### Introduction

Alfa Laval Industrial line is a wide product range that is used in virtually all types of industry.

Suitable for a wide range of applications, this model is available with a large selection of plate and gasket types.

### Applications

- Biotech and Pharmaceutical
- Chemicals
- Energy and Utilities
- Food, Dairy and Beverages
- Home and Personal care
- HVAC and Refrigeration
- Machinery and Manufacturing
- Marine and Transportation
- Mining, Minerals and Pigments
- Pulp and Paper
- Semiconductor and Electronics
- Steel
- Water and Waste treatment

### Benefits

- High energy efficiency – low operating cost
- Flexible configuration – heat transfer area can be modified
- Easy to install – compact design
- High serviceability – easy to open for inspection and cleaning and easy to clean by CIP
- Access to Alfa Laval's global service network

### Features

Every detail is carefully designed to ensure optimal performance, maximum uptime and easy maintenance. Selection of available features, depending on configuration some features may not be applicable:



- Five-point alignment
- T-bar roller
- CurveFlow™ distribution area
- Glued gasket
- ClipGrip™ gasket attachment
- Offset gasket groove
- OmegaPort™ noncircular port holes
- Leak chamber



- Elongated nut
- FlexFlow™ plate design
- Compact frame
- Bearing boxes
- Fixed bolt head
- Key hole bolt opening
- Lifting lug
- Lining
- Lock washer
- Tightening bolt cover

### Alfa Laval 360° Service Portfolio

Our extensive service offering ensure top performance from your Alfa Laval equipment throughout its life cycle. The Alfa Laval 360 Service Portfolio include installation services, cleaning and repair as well as spare parts, technical documentation and trouble shooting. We also offer replacement, retrofit, integrity testing, monitoring and much more.

For information about our complete service offering and how to contact us - please visit [www.alfalaval.com/service](http://www.alfalaval.com/service).

## Dimensional drawing

Measurements mm (inches)

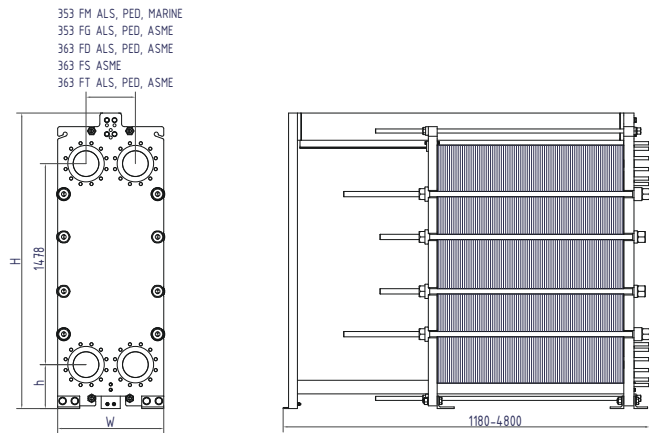

Frame type	H	W	h
FM ALS, PED, Marine <sup>1</sup>	2082.5 (81.9")	755 (29.7")	280 (11.0")
FG ALS, PED, ASME	2135 (84.0")	780 (30.7")	285 (11.2")
FD ALS, PED, ASME	2173 (85.5")	780 (30.7")	323 (12.7")
FS ASME	2173 (85.5")	780 (30.7")	323 (12.7")
FT ALS, PED, ASME	2173 (85.5")	780 (30.7")	323 (12.7")

<sup>1</sup> Marine includes the pressure vessel codes: ABS, BV, CCS, ClassNK, DNV, KR, LR, RINA, and RMRS.

## Technical data

Plates	Type	Free channel, mm (inches)
M	Single plate	3.97 (0.15)
P	Single plate	2.8 (0.11)
B	Single plate	1.92 (0.075)

### Materials

Heat transfer plates	304, 316, 254, C276, D205, C2000, Alloy 33, G30, Ni, Ti, TiPd
Field gaskets	NBR, EPDM, FKM, HNBR, HeatSeal
Flange connections	Metal lined: stainless steel, 254, C276, D205, C2000, G30, Ni, Ti, TiPd Rubber lined: NBR
Frame and pressure plate	Carbon steel, epoxy painted

Other materials may be available on request.

## Operational data

Frame type	Max. design pressure barg (psig)	Max. design temperature °C (°F)
FM, PED	10.4 (151)	200 (392)
FM, pvcALS	10.4 (151)	200 (392)
FM, Marine <sup>1</sup>	10.4 (151)	100 (212)
FG, pvcALS	16.0 (232)	200 (392)
FG, ASME	10.4 (151)	250 (482)
FG, PED	16.0 (232)	200 (392)
FD, pvcALS	25.0 (362)	200 (392)
FD, ASME	21.0 (304)	250 (482)
FD, PED	25.0 (362)	200 (392)
FS, ASME	36.0 (522)	250 (482)
FT, PED	40.0 (580)	200 (392)
FT, ALS	40.0 (580)	200 (392)
FT, ASME	41.4 (600)	250 (482)

<sup>1</sup> Marine includes the standards: ABS, BV, CCS, ClassNK, DNV, KR, LR, RINA, and RMRS.

Extended pressure and temperature rating may be available on request.

## General remarks for technical information

- The global offering presented in this leaflet may not be available for all regions
- All combinations may not be configurable

## Flange connections

Frame type	Connection standard
FM, pvcALS	EN 1092-1 DN200 PN10
	ASME B16.5 Class 150 NPS 8
	JIS B2220 10K 200A
FM, PED	EN 1092-1 DN200 PN10
	ASME B16.5 Class 150 NPS 8
FM, Marine <sup>1</sup>	EN 1092-1 DN200 PN10
	ASME B16.5 Class 150 NPS 8
	JIS B2220 10K 200A
FG, pvcALS	EN 1092-1 DN200 PN16
	EN 1092-1 DN200 PN25
	ASME B16.5 Class 150 NPS 8
	JIS B2220 16K 200A
FG, ASME	ASME B16.5 Class 150 NPS 8
	EN 1092-1 PN16
FG, PED	EN 1092-1 DN200 PN10
	EN 1092-1 DN200 PN16
	EN 1092-1 DN200 PN25
FD, pvcALS	ASME B16.5 Class 150 NPS 8
	EN 1092-1 DN200 PN25
	JIS B2220 20K 200A
	ASME B16.5 Class 300 NPS 8
FD, ASME	ASME B16.5 Class 150 NPS 8
	EN1092-1 PN25
	ASME B16.5 Class 300 NPS 8
FD, PED	EN 1092-1 DN200 PN25
	ASME B16.5 Class 300 NPS 8
FS, ASME	ASME B16.5 Class 300 NPS 8
	EN 1092-1 DN200 PN40
FT, ALS	ASME B16.5 Class 300 NPS 8
	ASME B16.5 Class 400 NPS 8
	JIS B2220 200A 30K
FT, PED	EN 1092-1 DN200 PN40
	ASME B16.5 Class 300 NPS 8
	ASME B16.5 Class 400 NPS 8
FT, ASME	ASME B16.5 Class 300 NPS 8
	ASME B16.5 Class 400 NPS 8
	EN 1092-1 DN200 PN40

<sup>1</sup> Marine includes the standards: ABS, BV, CCS, DNV, ClassNK, KR, LR, RINA, and RMRS.

Standard EN1092-1 corresponds to GOST 12815-80 and GB/T9124.1.



# Alfa Laval T25

## Gasketed plate heat exchanger for a wide range of applications

### Introduction

Alfa Laval Industrial line is a wide product range that is used in virtually all types of industry.

Designed for high throughput, this model delivers excellent thermal performance. A large selection of plate and gasket types is available.

### Applications

- Biotech and Pharmaceutical
- Chemicals
- Energy and Utilities
- Food, Dairy and Beverages
- Home and Personal care
- HVAC and Refrigeration
- Machinery and Manufacturing
- Marine and Transportation
- Mining, Minerals and Pigments
- Pulp and Paper
- Semiconductor and Electronics
- Steel
- Water and Waste treatment

### Benefits

- High energy efficiency – low operating cost
- Flexible configuration – heat transfer area can be modified
- Easy to install – compact design
- High serviceability – easy to open for inspection and cleaning and easy to clean by CIP
- Access to Alfa Laval's global service network

### Features

Every detail is carefully designed to ensure optimal performance, maximum uptime and easy maintenance. Selection of available features, depending on configuration some features may not be applicable:



- Five-point alignment
- T-bar roller
- CurveFlow™ distribution area
- PowerArc™ plate pattern divider
- ClipGrip™ gasket attachment
- Offset gasket groove
- OmegaPort™ noncircular port holes

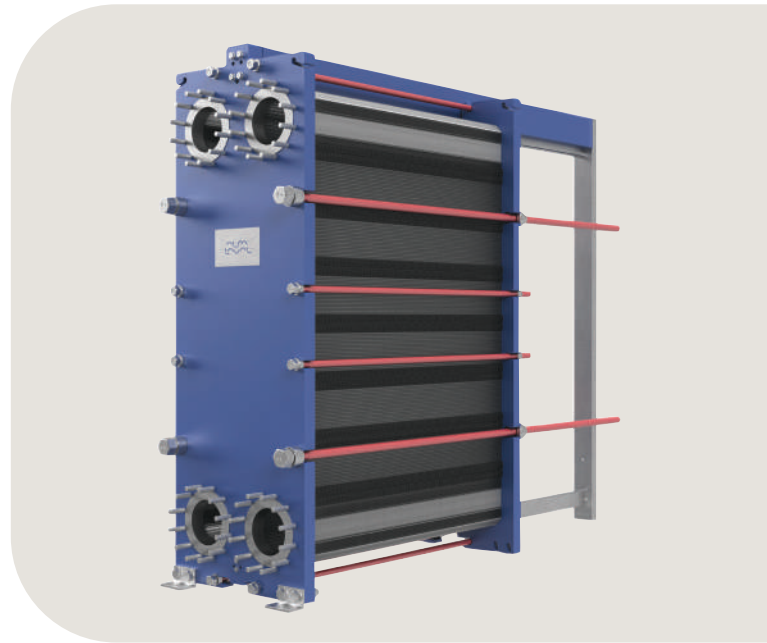

- Leak chamber
- FlexFlow™ plate design
- Bearing boxes
- Fixed bolt head
- Key hole bolt opening
- Lifting lug
- Lining
- Lock washer
- Tightening bolt cover

### Alfa Laval 360° Service Portfolio

Our extensive service offering ensure top performance from your Alfa Laval equipment throughout its life cycle. The Alfa Laval 360 Service Portfolio include installation services, cleaning and repair as well as spare parts, technical documentation and trouble shooting. We also offer replacement, retrofit, integrity testing, monitoring and much more.

For information about our complete service offering and how to contact us - please visit [www.alfalaval.com/service](http://www.alfalaval.com/service).

## Dimensional drawing

Measurements mm (inches)

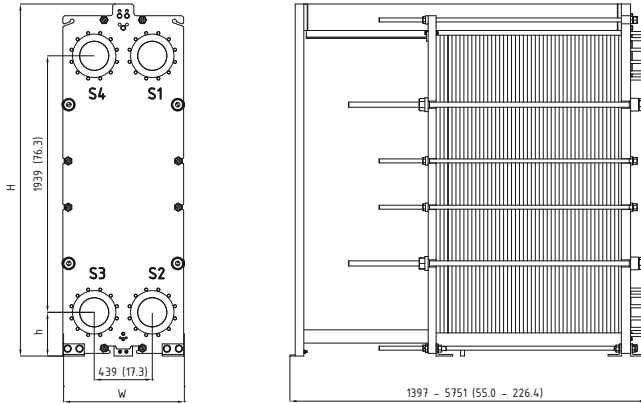

Frame	H	W	h
FM pvcALS, PED, Marine <sup>1</sup>	2661 (104.8")	913 (35.9")	331 (13.0")
FG pvcALS, ASME, PED	2661 (104.8")	913 (35.9")	331 (13.0")
FD pvcALS, PED	2711 (106.7")	913 (35.9")	331 (13.0")
FD ASME	2711 (106.7")	942 (37.1")	331 (13.0")
FS pvcALS	2711 (106.7")	913 (35.9")	331 (13.0")
FS ASME	2711 (106.7")	942 (37.1")	331 (13.0")

<sup>1</sup> Marine includes the pressure vessel codes: ABS, BV, CCS, ClassNK, DNV, KR, LR, RINA, and RMRS.

The number of tightening bolts may vary depending on pressure rating.

## Technical data

Plates	Type	Free channel, mm (inches)
B	Single plate	2.00 (0.079)
P	Single plate	2.90 (0.114)
M	Single plate	3.82 (0.15)

## Materials

Heat transfer plates	304/304L, 316/316L, 254, C276, TiPd Ti
Field gaskets	NBR, EPDM, FKM, HNBR
Flange connections	Metal lined: stainless steel, Alloy 254, Alloy C276,
	titanium Rubber lined: NBR, EPDM
Frame and pressure plate	Carbon steel, epoxy painted

Other materials may be available on request.

## Operational data

Frame type	Max. design pressure barg (psig)	Max. design temperature °C (°F)
FM, PED	11.5 (188)	180 (356)
FM, pvcALS	10.3 (150)	180 (356)
FM, Marine <sup>1</sup>	10.0 (145)	100 (212)
FG, pvcALS	16.0 (232)	180 (356)
FG, ASME	10.4 (151)	250 (482)
FG, PED	16.0 (232)	150 (302)
FD, pvcALS	25.0 (362)	180 (356)
FD, ASME	20.7 (300)	250 (482)
FD, PED	25.0 (362)	180 (356)
FS, pvcALS	30.0 (434)	180 (356)
FS, ASME	27.6 (400)	250 (482)

<sup>1</sup> Marine includes the standards: ABS, BV, CCS, ClassNK, DNV, KR, LR, RINA, and RMRS.

## General remarks for technical information

- The global offering presented in this leaflet may not be available for all regions
- All combinations may not be configurable

## Flange connections

Frame type	Connection standard
FM, pvcALS	EN 1092-1 DN200 PN10
	EN 1092-1 DN250 PN10
	EN 1092-1 DN300 PN10
	ASME B16.5 Class 150 NPS 8
	ASME B16.5 Class 150 NPS 10
FM, PED	JIS B2220 10K 200A
	JIS B2220 10K 250A
	EN 1092-1 DN200 PN10
	EN 1092-1 DN250 PN10
	ASME B16.5 Class 150 NPS 8
FM, Marine <sup>1</sup>	ASME B16.5 Class 150 NPS 10
	EN 1092-1 DN200 PN10
	EN 1092-1 DN250 PN10
	ASME B16.5 Class 150 NPS 8
	ASME B16.5 Class 150 NPS 10
FG, pvcALS	JIS B2220 10K 200A
	JIS B2220 10K 250A
	EN 1092-1 DN200 PN16
	EN 1092-1 DN250 PN16
	EN 1092-1 DN300 PN16
FG, ASME	ASME B16.5 Class 150 NPS 8
	ASME B16.5 Class 150 NPS 10
	EN 1092-1 DN200 PN16
	EN 1092-1 DN250 PN16
	EN 1092-1 DN300 PN16
FG, PED	ASME B16.5 Class 150 NPS 8
	ASME B16.5 Class 150 NPS 10
	EN 1092-1 DN200 PN25
	EN 1092-1 DN250 PN25
	ASME B16.5 Class 300 NPS 8
FD, pvcALS	ASME B16.5 Class 300 NPS 10
	JIS B2220 20K 200A
	JIS B2220 20K 250A
	ASME B16.5 Class 150 NPS 8
	ASME B16.5 Class 150 NPS 10
FD, ASME	ASME B16.5 Class 300 NPS 8
	ASME B16.5 Class 300 NPS 10
	EN 1092-1 DN200 PN25
	EN 1092-1 DN250 PN25
	ASME B16.5 Class 300 NPS 8
FD, PED	ASME B16.5 Class 300 NPS 10
	EN 1092-1 DN200 PN40
	EN 1092-1 DN250 PN40
	ASME B16.5 Class 400 NPS 8
	ASME B16.5 Class 400 NPS 10
FS, pvcALS	JIS B2220 30K 200A
	JIS B2220 30K 250A
	ASME B16.5 Class 300 NPS 8
	ASME B16.5 Class 300 NPS 10
	ASME B16.5 Class 300 NPS 10

<sup>1</sup> Marine includes the standards: ABS, BV, CCS, DNV, ClassNK, KR, LR, RINA, and RMRS.

Standard EN1092-1 corresponds to GOST 12815-80 and GB/T9124.1.

Extended pressure and temperature rating may be available on request.

# Alfa Laval T35

## Gasketed plate heat exchanger for a wide range of applications

### Introduction

Alfa Laval Industrial line is a wide product range that is used in virtually all types of industry.

Designed for high throughput, this model delivers excellent thermal performance. A large selection of plate and gasket types is available.

### Applications

- Biotech and Pharmaceutical
- Chemicals
- Energy and Utilities
- Food, Dairy and Beverages
- Home and Personal care
- HVAC and Refrigeration
- Machinery and Manufacturing
- Marine and Transportation
- Mining, Minerals and Pigments
- Pulp and Paper
- Semiconductor and Electronics
- Steel
- Water and Waste treatment

### Benefits

- High energy efficiency – low operating cost
- Flexible configuration – heat transfer area can be modified
- Easy to install – compact design
- High serviceability – easy to open for inspection and cleaning and easy to clean by CIP
- Access to Alfa Laval's global service network

### Features

Every detail is carefully designed to ensure optimal performance, maximum uptime and easy maintenance. Selection of available features, depending on configuration some features may not be applicable:



- Five-point alignment
- Reinforced hanger
- T-bar roller
- CurveFlow™ distribution area
- Glued gasket
- PowerArc™ plate pattern divider
- ClipGrip™ gasket attachment

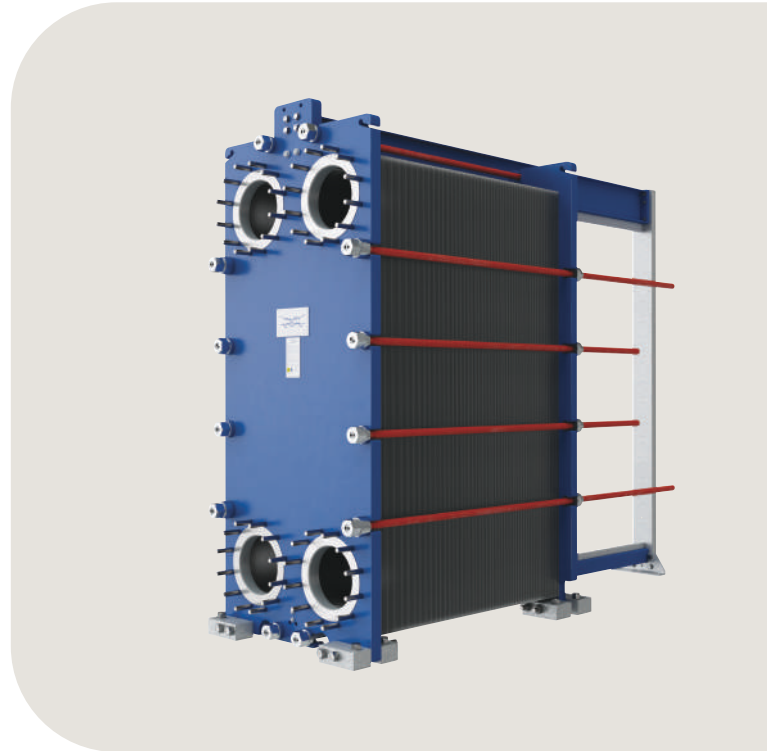

- Offset gasket groove
- OmegaPort™ noncircular port holes
- Leak chamber
- Bearing boxes
- Fixed bolt head
- Key hole bolt opening
- Lifting lug
- Lining
- Lock washer
- Swing feet
- Tightening bolt cover

### Alfa Laval 360° Service Portfolio

Our extensive service offering ensure top performance from your Alfa Laval equipment throughout its life cycle. The Alfa Laval 360 Service Portfolio include installation services, cleaning and repair as well as spare parts, technical documentation and trouble shooting. We also offer replacement, retrofit, integrity testing, monitoring and much more.

## Dimensional drawing

Measurements mm (inches)

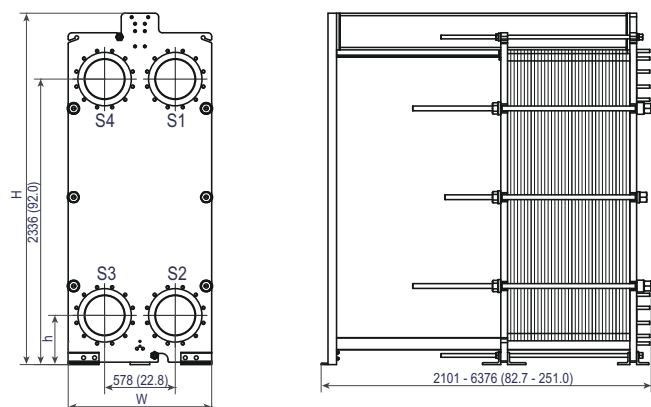

Frame type	H	W	h
FL, ALS	2875 (113.2")	1174 (46.2")	403 (15.9")
FM, ALS, PED, Marine <sup>1</sup>	2875 (113.2")	1174 (46.2")	403 (15.9")
FG, ALS, ASME, PED	2875 (113.2")	1174 (46.2")	403 (15.9")
FD, ALS, ASME, PED	2875 (113.2")	1174 (46.2")	403 (15.9")
FS, PED	2875 (113.2")	1174 (46.2")	403 (15.9")
FS, ASME	2875 (113.2")	1187 (46.7")	403 (15.9")

<sup>1</sup> Marine includes the pressure vessel codes: ABS, BV, CCS, ClassNK, DNV, KR, LR, RINA, and RMRS.

The number of tightening bolts may vary depending on pressure rating.

## Technical data

Plates	Type	Free channel, mm (inches)
P	Single plate	3.4 (0.13)

### Materials

	304/304L, 316/316L, 904L, 254 C276, C2000
Heat transfer plates	G30 Ti, TiPd Ti, TiPd
Field gaskets	NBR, EPDM, FKM
Flange connections	Carbon steel Metal lined: stainless steel Alloy 316, titanium
Frame and pressure plate	Carbon steel, epoxy painted

Other materials may be available on request.

## Operational data

Frame type	Max. design pressure barg (psig)	Max. design temperature °C (°F)
FL, pvcALS	6.0 (87)	100 (212)
FM, PED	10.3 (150)	180 (356)
FM, pvcALS	10.3 (150)	120 (248)
FM, Marine <sup>1</sup>	10.0 (145)	100 (212)
FG, pvcALS	16.0 (232)	180 (356)
FG, ASME	10.3 (150)	250 (482)
FG, PED	16.0 (232)	180 (356)
FD, pvcALS	25.0 (362)	180 (356)
FD, ASME	20.7 (300)	250 (482)
FD, PED	25.0 (362)	180 (356)
FS, ASME	27.6 (400)	250 (482)
FS, PED	30.0 (435)	180 (356)

<sup>1</sup> Marine includes the standards: ABS, BV, CCS, ClassNK, DNV, KR, LR, RINA, and RMRS.

Extended pressure and temperature rating may be available on request.

## General remarks for technical information

- The global offering presented in this leaflet may not be available for all regions
- All combinations may not be configurable

## Flange connections

Frame type	Connection standard
FL, pvcALS	EN 1092-1 DN300 PN10
	EN 1092-1 DN350 PN10
	ASME B16.5 Class 150 NPS 12
	ASME B16.5 Class 150 NPS 14
	JIS B2220 10K 300A JIS B2220 10K 350A
FM, pvcALS	EN 1092-1 DN300 PN10
	EN 1092-1 DN350 PN10
	ASME B16.5 Class 150 NPS 12
	ASME B16.5 Class 150 NPS 14 JIS B2220 10K 300A JIS B2220 10K 350A
FM, PED	EN 1092-1 DN300 PN10
	EN 1092-1 DN350 PN10
FM, Marine <sup>1</sup>	ASME B16.5 Class 150 NPS 12
	ASME B16.5 Class 150 NPS 14
	EN 1092-1 DN300 PN10
	EN 1092-1 DN350 PN10
	ASME B16.5 Class 150 NPS 6 JIS B2220 10K 300A JIS B2220 10K 350A
FG, pvcALS	EN 1092-1 DN300 PN16
	EN 1092-1 DN350 PN16
	ASME B16.5 Class 150 NPS 12
	ASME B16.5 Class 150 NPS 14
	JIS B2220 16K 300A JIS B2220 16K 350A
FG, ASME	ASME B16.5 Class 150 NPS 12
	ASME B16.5 Class 150 NPS 14
FG, PED	EN 1092-1 DN300 PN16
	EN 1092-1 DN350 PN16
	ASME B16.5 Class 150 NPS 12 ASME B16.5 Class 150 NPS 14
FD, pvcALS	EN 1092-1 DN300 PN25
	EN 1092-1 DN350 PN25
	ASME B16.5 Class 300 NPS 12
	ASME B16.5 Class 300 NPS 14 JIS B2220 20K 300A JIS B2220 20K 350A
FD, ASME	ASME B16.5 Class 300 NPS 12
	ASME B16.5 Class 300 NPS 14
FD, PED	EN 1092-1 DN300 PN25
	EN 1092-1 DN350 PN25
	ASME B16.5 Class 300 NPS 12 ASME B16.5 Class 300 NPS 14
FS, ASME	ASME B16.5 Class 400 NPS 12
	ASME B16.5 Class 400 NPS 14
FS, PED	ASME B16.5 Class 300 NPS 12
	ASME B16.5 Class 300 NPS 14
	ASME B16.5 Class 400 NPS 12 ASME B16.5 Class 400 NPS 14

<sup>1</sup> Marine includes the standards: ABS, BV, CCS, DNV, ClassNK, KR, LR, RINA, and RMRS.

Standard EN1092-1 corresponds to GOST 12815-80 and GB/T9124.1.

# Alfa Laval T45

## Gasketed plate heat exchanger for a wide range of applications

### Introduction

Alfa Laval Industrial line is a wide product range that is used in virtually all types of industry.

Designed for high throughput, this model delivers excellent thermal performance. A large selection of plate and gasket types is available.

### Applications

- Biotech and Pharmaceutical
- Chemicals
- Energy and Utilities
- Food, Dairy and Beverages
- Home and Personal care
- HVAC and Refrigeration
- Machinery and Manufacturing
- Marine and Transportation
- Mining, Minerals and Pigments
- Pulp and Paper
- Semiconductor and Electronics
- Steel
- Water and Waste treatment

### Benefits

- High energy efficiency – low operating cost
- Flexible configuration – heat transfer area can be modified
- Easy to install – compact design
- High serviceability – easy to open for inspection and cleaning and easy to clean by CIP
- Access to Alfa Laval's global service network

### Features

Every detail is carefully designed to ensure optimal performance, maximum uptime and easy maintenance. Selection of available features, depending on configuration some features may not be applicable:



- Five-point alignment
- Reinforced hanger
- Chocolate pattern distribution area
- T-bar roller
- Glued gasket
- Base-ad gasket
- Offset gasket groove

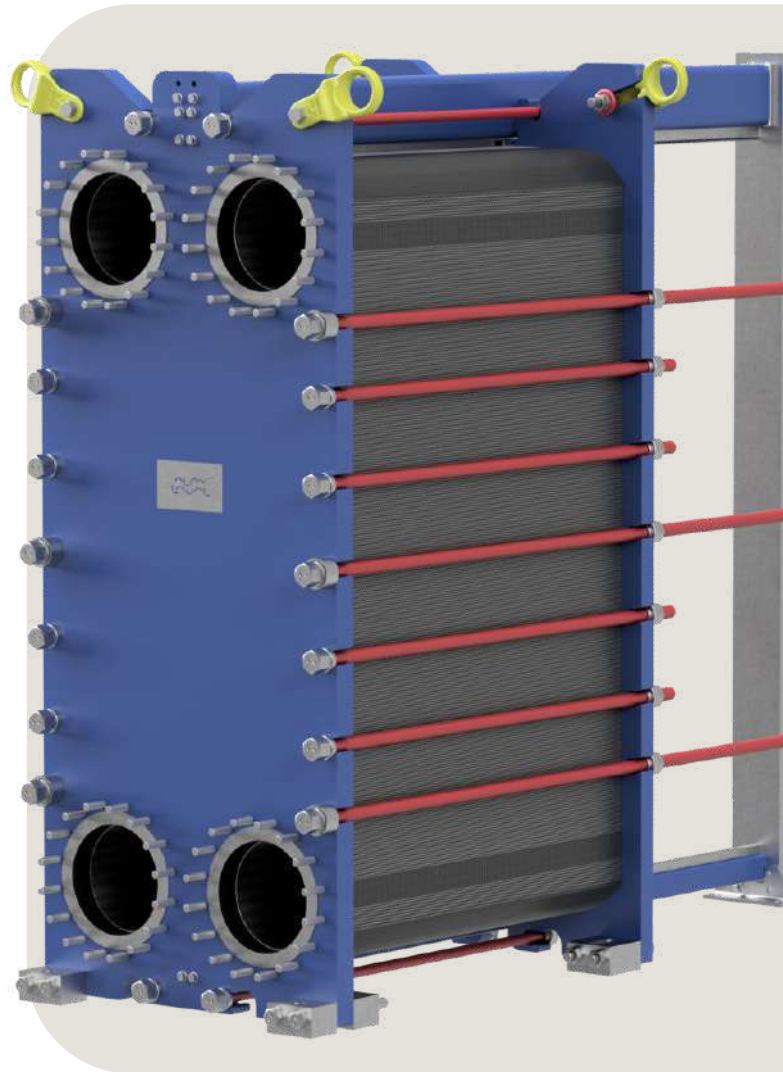

- Leak chamber
- Bearing boxes
- Fixed bolt head
- Key hole bolt opening
- Lifting lug
- Lining
- Lock washer
- Swing feet
- Tightening bolt cover

## Dimensional drawing

Measurements mm (inches)

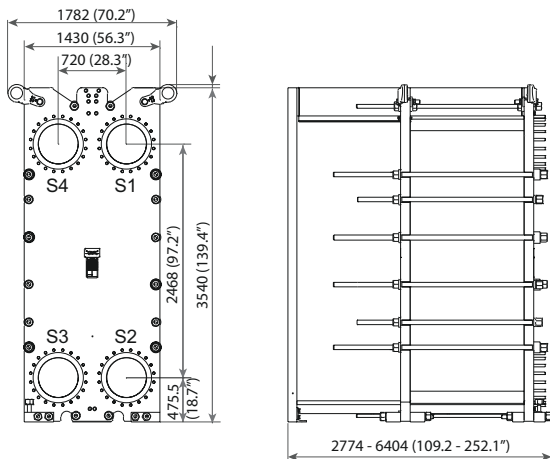

The number of tightening bolts may vary depending on pressure rating.

## Technical data

Plates	Type	Free channel, mm (inches)
M	Single plate	4.0 (0.16)

### Materials

Heat transfer plates	304, 316, 254 Ti
Field gaskets	NBR, EPDM, HNBR
Flange connections	Carbon steel Metal lined: stainless steel, Alloy 254, titanium
Frame and pressure plate	Carbon steel, epoxy painted

Other materials may be available on request.

## Operational data

Frame type	Max. design pressure barg (psig)	Max. design temperature °C (°F)
FM, pvcALS	11.0 (159)	200 (392)
FG, pvcALS	18.0 (261)	200 (392)
FG, ASME	10.4 (151)	250 (482)
FG, PED	18.0 (261)	250 (482)
FD, ASME	17.4 (252)	250 (482)

Extended pressure and temperature rating may be available on request.

## General remarks for technical information

- The global offering presented in this leaflet may not be available for all regions
- All combinations may not be configurable

## Flange connections

Frame type	Connection standard
FM, pvcALS	EN 1092-1 DN450 PN10
	EN 1092-1 DN500 PN10
	ASME B16.5 Class 150 NPS 18
	ASME B16.5 Class 150 NPS 20
	JIS B2220 10K 450A JIS B2220 10K 500A
FG, pvcALS	EN 1092-1 DN450 PN16
	ASME B16.5 Class 150 NPS 18 JIS B2220 16K 450A
FG, ASME	ASME B16.5 Class 150 NPS 18
FG, PED	EN 1092-1 DN450 PN16
	ASME B16.5 Class 150 NPS 18
FD, ASME	ASME B16.5 Class 150 NPS 18
	ASME B16.5 Class 300 NPS 18

Standard EN1092-1 corresponds to GOST 12815-80 and GB/T9124.1.

This document and its contents are subject to copyrights and other intellectual property rights owned by Alfa Laval AB (publ) or any of its affiliates (jointly "Alfa Laval"). No part of this document may be copied, re-produced or transmitted in any form or by any means, or for any purpose, without Alfa Laval's prior express written permission. Information and services provided in this document are made as a benefit and service to the user, and no representations or warranties are made about the accuracy or suitability of this information and these services for any purpose. All rights are reserved.

## How to contact Alfa Laval

Up-to-date Alfa Laval contact details for all countries are always available on our website at [www.alfalaval.com](http://www.alfalaval.com)

# Alfa Laval T50

## Gasketed plate heat exchanger for a wide range of applications

### Introduction

Alfa Laval Industrial line is a wide product range that is used in virtually all types of industry.

Designed for high throughput, this model delivers excellent thermal performance. A large selection of plate and gasket types is available.

### Applications

- Biotech and Pharmaceutical
- Chemicals
- Energy and Utilities
- Food, Dairy and Beverages
- Home and Personal care
- HVAC and Refrigeration
- Machinery and Manufacturing
- Marine and Transportation
- Mining, Minerals and Pigments
- Pulp and Paper
- Semiconductor and Electronics
- Steel
- Water and Waste treatment

### Benefits

- High energy efficiency – low operating cost
- Flexible configuration – heat transfer area can be modified
- Easy to install – compact design
- High serviceability – easy to open for inspection and cleaning and easy to clean by CIP
- Access to Alfa Laval's global service network

### Features

Every detail is carefully designed to ensure optimal performance, maximum uptime and easy maintenance. Selection of available features, depending on configuration some features may not be applicable:



- Five-point alignment
- Reinforced hanger
- Chocolate pattern distribution area
- Glued gasket
- Base-ad gasket
- Leak chamber
- Bearing boxes

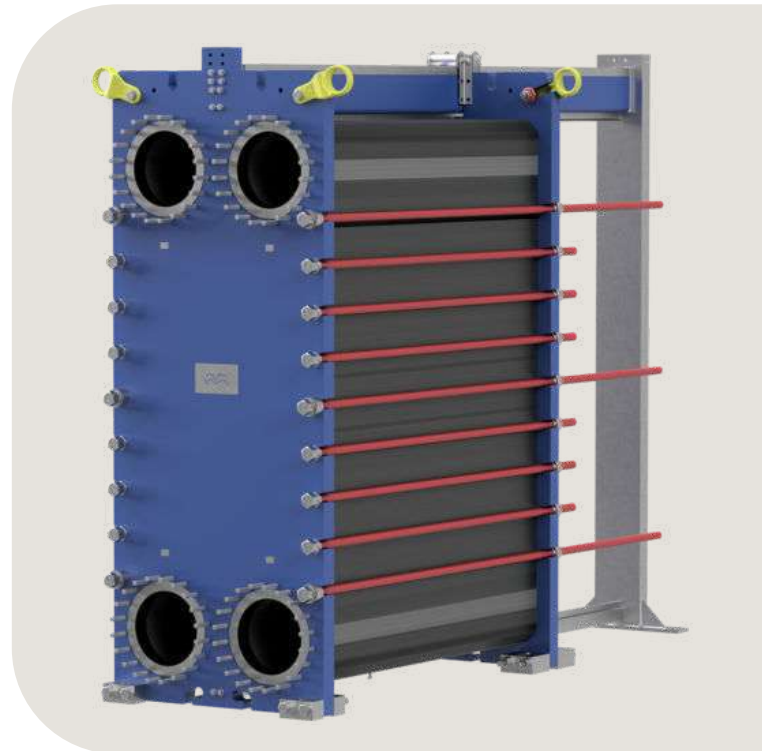

- Fixed bolt head
- Key hole bolt opening
- Lifting lug
- Lining
- Lock washer
- Pressure plate roller
- Tightening bolt cover

### Alfa Laval 360° Service Portfolio

Our extensive service offering ensure top performance from your Alfa Laval equipment throughout its life cycle. The Alfa Laval 360 Service Portfolio include installation services, cleaning and repair as well as spare parts, technical documentation and trouble shooting. We also offer replacement, retrofit, integrity testing, monitoring and much more.

For information about our complete service offering and how to contact us - please visit [www.alfalaval.com/service](http://www.alfalaval.com/service).

## Dimensional drawing

Measurements mm (inches)

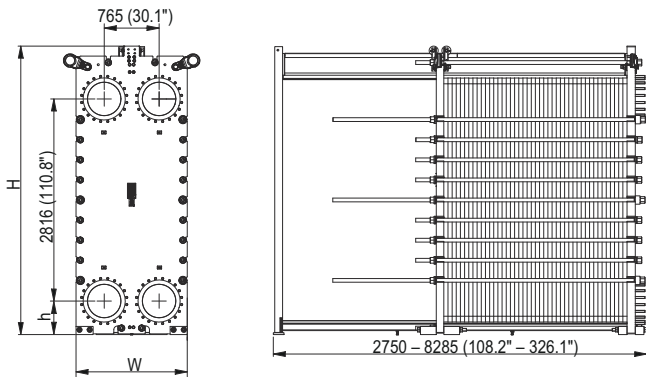

Frame type	H	W	h
FM	4010 (157.8")	1550 (61.0")	467 (18.4")
FG	4010 (157.8")	1550 (61.0")	467 (18.4")
FD	4010 (157.8")	1550 (61.0")	467 (18.4")

The number of tightening bolts may vary depending on pressure rating.

## Technical data

Plates	Type	Free channel, mm (inches)
M	Single plate	3.9 (0.15)

### Materials

Heat transfer plates	316/316L Ti
Field gaskets	NBR, EPDM, HNBR
Flange connections	Carbon steel Metal lined: stainless steel, titanium
Frame and pressure plate	Carbon steel, epoxy painted

Other materials may be available on request.

## Operational data

Frame type	Max. design pressure barg (psig)	Max. design temperature °C (°F)
FM, pvcALS	11.0 (159)	200 (392)
FG, ASME	10.3 (150)	250 (482)
FG, PED	20.0 (290)	200 (392)
FD, ASME	20.7 (300)	250 (482)
FD, PED	31.3 (453.9)	200 (392)

Extended pressure and temperature rating may be available on request.

## General remarks for technical information

- The global offering presented in this leaflet may not be available for all regions
- All combinations may not be configurable

## Flange connections

Frame type	Connection standard
FM, pvcALS	EN 1092-1 DN500 PN10
	ASME B16.5 Class 150 NPS 20
	HG/T 20615 Class 150
FG, ASME	ASME B16.5 Class 150 NPS 20
	ASME B16.5 Class 300 NPS 20
FG, PED	EN 1092-1 DN500 PN10
	EN 1092-1 DN500 PN16
	ASME B16.5 Class 300 NPS 20
FD, ASME	ASME B16.5 Class 150 NPS 20
	ASME B16.5 Class 300 NPS 20
FD, PED	EN 1092-1 DN500 PN25
	ASME B16.5 Class 300 NPS 20

Standard EN1092-1 corresponds to GOST 12815-80 and GB/T9124.1.

This document and its contents are subject to copyrights and other intellectual property rights owned by Alfa Laval AB (publ) or any of its affiliates (jointly "Alfa Laval"). No part of this document may be copied, re-produced or transmitted in any form or by any means, or for any purpose, without Alfa Laval's prior express written permission. Information and services provided in this document are made as a benefit and service to the user, and no representations or warranties are made about the accuracy or suitability of this information and these services for any purpose. All rights are reserved.

# Alfa Laval TL3

## Gasketed plate heat exchanger for a wide range of applications

### Introduction

Alfa Laval Industrial line is a wide product range that is used in virtually all types of industry.

The relatively tall plate makes this model suitable for duties with long temperature programs and when high heat recovery is appreciated. A large range of plate and gasket types is available.

In addition to normal single plate configuration, this model is also available with double wall plates. Double wall plates are used as an extra precaution to avoid intermixing of fluids.

### Applications

- Biotech and Pharmaceutical
- Chemicals
- Energy and Utilities
- Food, Dairy and Beverages
- Home and Personal care
- HVAC and Refrigeration
- Machinery and Manufacturing
- Marine and Transportation
- Mining, Minerals and Pigments
- Pulp and Paper
- Semiconductor and Electronics
- Steel
- Water and Waste treatment

### Benefits

- High energy efficiency – low operating cost
- Flexible configuration – heat transfer area can be modified
- Easy to install – compact design
- High serviceability – easy to open for inspection and cleaning and easy to clean by CIP
- Access to Alfa Laval's global service network

### Features

Every detail is carefully designed to ensure optimal performance, maximum uptime and easy maintenance. Selection of available features, depending on configuration some features may not be applicable:



- Corner guided alignment system
- Clip-on gasket

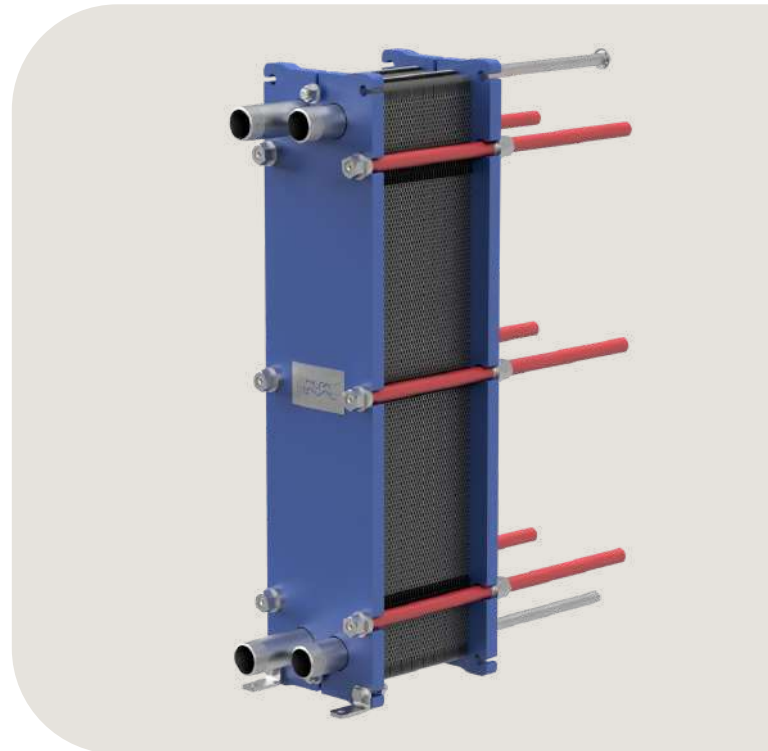

- Offset gasket groove
- Leak chamber
- Fixed bolt head
- Key hole bolt opening
- Lifting lug
- Lining
- Lock washer
- Tightening bolt cover

### Alfa Laval 360° Service Portfolio

Our extensive service offering ensure top performance from your Alfa Laval equipment throughout its life cycle. The Alfa Laval 360 Service Portfolio include installation services, cleaning and repair as well as spare parts, technical documentation and trouble shooting. We also offer replacement, retrofit, integrity testing, monitoring and much more.

For information about our complete service offering and how to contact us - please visit [www.alfalaval.com/service](http://www.alfalaval.com/service).

### General remarks for technical information

- The global offering presented in this leaflet may not be available for all regions
- All combinations may not be configurable

### Dimensional drawing

Measurements mm (inches)

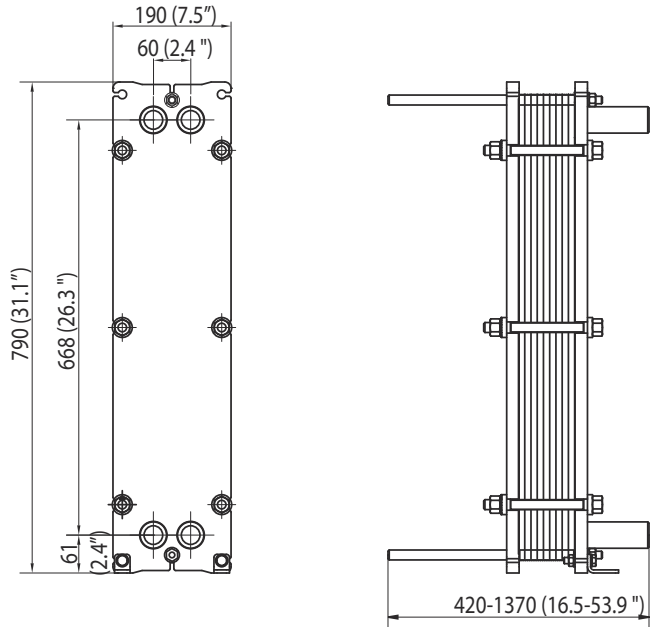

Extended pressure and temperature rating may be available on request.

### Pipe connections

Connection type	Connection standard
Threaded port	ISO 228 - G 1 1/4
External tapered threaded	ISO 7 - R 1 1/4 1 1/4 - 11.5 NPT

Other connection types may be available on request.

### Technical data

Plates	Type	Free channel, mm (inches)
B	Single plate	1.8 (0.07)
P	Single plate	3.0 (0.12)
BD	Double wall plate	1.8 (0.07)

### Materials

Heat transfer plates	304/304L, 316/316L, 254 Ti
Field gaskets	NBR, EPDM, FKM
Pipe connections	Stainless steel, titanium
Frame and pressure plate	Carbon steel, epoxy painted

Other materials may be available on request.

### Operational data

Frame type	Max. design pressure barg (psig)	Max. design temperature °C (°F)
FG, pvcALS	16.0 (232)	180 (356)
FG, ASME	10.3 (150)	180 (356)
FG, PED	16.0 (232)	180 (356)

This document and its contents are subject to copyrights and other intellectual property rights owned by Alfa Laval AB (publ) or any of its affiliates (jointly "Alfa Laval"). No part of this document may be copied, re-produced or transmitted in any form or by any means, or for any purpose, without Alfa Laval's prior express written permission. Information and services provided in this document are made as a benefit and service to the user, and no representations or warranties are made about the accuracy or suitability of this information and these services for any purpose. All rights are reserved.

### How to contact Alfa Laval

Up-to-date Alfa Laval contact details for all countries are always available on our website at [www.alfalaval.com](http://www.alfalaval.com)



# Alfa Laval TL6

## Gasketed plate heat exchanger for a wide range of applications

### Introduction

Alfa Laval Industrial line is a wide product range that is used in virtually all types of industry.

The relatively tall plate makes this model suitable for duties with long temperature programs and when high heat recovery is appreciated. A large range of plate and gasket types is available.

### Applications

- Biotech and Pharmaceutical
- Chemicals
- Energy and Utilities
- Food, Dairy and Beverages
- Home and Personal care
- HVAC and Refrigeration
- Machinery and Manufacturing
- Marine and Transportation
- Mining, Minerals and Pigments
- Pulp and Paper
- Semiconductor and Electronics
- Steel
- Water and Waste treatment

### Benefits

- High energy efficiency – low operating cost
- Flexible configuration – heat transfer area can be modified
- Easy to install – compact design
- High serviceability – easy to open for inspection and cleaning and easy to clean by CIP
- Access to Alfa Laval's global service network

### Features

Every detail is carefully designed to ensure optimal performance, maximum uptime and easy maintenance. Selection of available features, depending on configuration some features may not be applicable:



- Corner guided alignment system
- Chocolate pattern distribution area
- Clip-on gasket
- Offset gasket groove
- Leak chamber
- Compact frame



- Fixed bolt head
- Key hole bolt opening
- Lifting lug
- Lining
- Lock washer
- Tightening bolt cover

### Alfa Laval 360° Service Portfolio

Our extensive service offering ensure top performance from your Alfa Laval equipment throughout its life cycle. The Alfa Laval 360 Service Portfolio include installation services, cleaning and repair as well as spare parts, technical documentation and trouble shooting. We also offer replacement, retrofit, integrity testing, monitoring and much more.

For information about our complete service offering and how to contact us - please visit [www.alfalaval.com/service](http://www.alfalaval.com/service).

## General remarks for technical information

- The global offering presented in this leaflet may not be available for all regions
- All combinations may not be configurable

## Dimensional drawing

Measurements mm (inches)

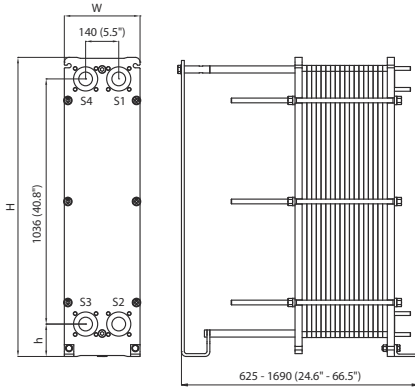

Frame type	H	W	h
FM	1264 (49.8")	320 (12.6")	137 (5.4")
FG	1264 (49.8")	320 (12.6")	137 (5.4")
FG, ASME	1299 (51.1")	320 (12.6")	142 (5.6")
FD	1264 (49.8")	330 (13.0")	137 (5.4")
FD, ASME	1308 (51.5")	330 (13.0")	142 (5.6")

The number of tightening bolts may vary depending on pressure rating.

## Technical data

Plates	Type	Free channel, mm (inches)
B	Single plate	1.8 (0.071)

## Materials

Heat transfer plates	304, 316, Ni Ti
Field gaskets	NBR, EPDM, FKM, HeatSeal Carbon steel
Flange connections	Metal lined: stainless steel, titanium Rubber lined: NBR, EPDM
Pipe connections	Stainless steel
Frame and pressure plate	Carbon steel, epoxy painted

Other materials may be available on request.

## Operational data

Frame type	Max. design pressure barg (psig)	Max. design temperature °C (°F)
FM, PED	10.0 (145)	180 (356)
FM, pvcALS	10.0 (145)	180 (356)
FG, pvcALS	16.0 (232)	180 (356)
FG, ASME	10.3 (150)	250 (482)

Frame type	Max. design pressure barg (psig)	Max. design temperature °C (°F)
FG, PED	16.0 (232)	180 (356)
FD, pvcALS	25.0 (362)	180 (356)
FD, ASME	20.7 (300)	250 (482)
FD, PED	25.0 (362)	180 (356)

Extended pressure and temperature rating may be available on request.

## Flange connections

Frame type	Connection standard	
FM, pvcALS	EN 1092-1 DN50 PN16	
	EN 1092-1 DN65 PN16	
	ASME B16.5 Class 150 NPS 2	
	JIS B2220 10K 50A JIS B2220 10K 65A	
FM, PED	EN 1092-1 DN50 PN16	
	EN 1092-1 DN65 PN16	
	ASME B16.5 Class 150 NPS 2	
	EN 1092-1 DN50 PN16 EN 1092-1 DN65 PN16 ASME B16.5 Class 150 NPS 2	
FG, pvcALS	JIS B2220 10K 50A JIS B2220 10K 65A JIS B2220 16K 50A JIS B2220 16K 65A	
	FG, ASME	ASME B16.5 Class 150 NPS 2
	FG, PED	EN 1092-1 DN50 PN16 EN 1092-1 DN65 PN16 ASME B16.5 Class 150 NPS 2
		FD, pvcALS
FD, ASME		
	FD, PED	

Standard EN1092-1 corresponds to GOST 12815-80 and GB/T9124.1.

## Pipe connections

Connection type	Connection standard
Threaded port	ISO 228 - G 2
External parallel threaded	ISO 228 - G 2 B
External tapered threaded	ISO 7 - R 2
Radial grooved pipe	NPS 2
External thread	2 - 11.5 NPT

Other connection types may be available on request.

This document and its contents are subject to copyrights and other intellectual property rights owned by Alfa Laval AB (publ) or any of its affiliates (jointly "Alfa Laval"). No part of this document may be copied, re-produced or transmitted in any form or by any means, or for any purpose, without Alfa Laval's prior express written permission. Information and services provided in this document are made as a benefit and service to the user, and no representations or warranties are made about the accuracy or suitability of this information and these services for any purpose. All rights are reserved.

## How to contact Alfa Laval

Up-to-date Alfa Laval contact details for all countries are always available on our website at [www.alfalaval.com](http://www.alfalaval.com)

# Alfa Laval TL10

## Gasketed plate heat exchanger for a wide range of applications

### Introduction

Alfa Laval Industrial line is a wide product range that is used in virtually all types of industry.

The relatively tall plate makes this model suitable for duties with long temperature programs and when high heat recovery is appreciated. A large range of plate and gasket types is available.

### Applications

- Biotech and Pharmaceutical
- Chemicals
- Energy and Utilities
- Food, Dairy and Beverages
- Home and Personal care
- HVAC and Refrigeration
- Machinery and Manufacturing
- Marine and Transportation
- Mining, Minerals and Pigments
- Pulp and Paper
- Semiconductor and Electronics
- Steel
- Water and Waste treatment

### Benefits

- High energy efficiency – low operating cost
- Flexible configuration – heat transfer area can be modified
- Easy to install – compact design
- High serviceability – easy to open for inspection and cleaning and easy to clean by CIP
- Access to Alfa Laval's global service network

### Features

Every detail is carefully designed to ensure optimal performance, maximum uptime and easy maintenance. Selection of available features, depending on configuration some features may not be applicable:



- Five-point alignment
- Corner guided alignment system
- Chocolate pattern distribution area
- Glued gasket
- Clip-on gasket
- Offset gasket groove

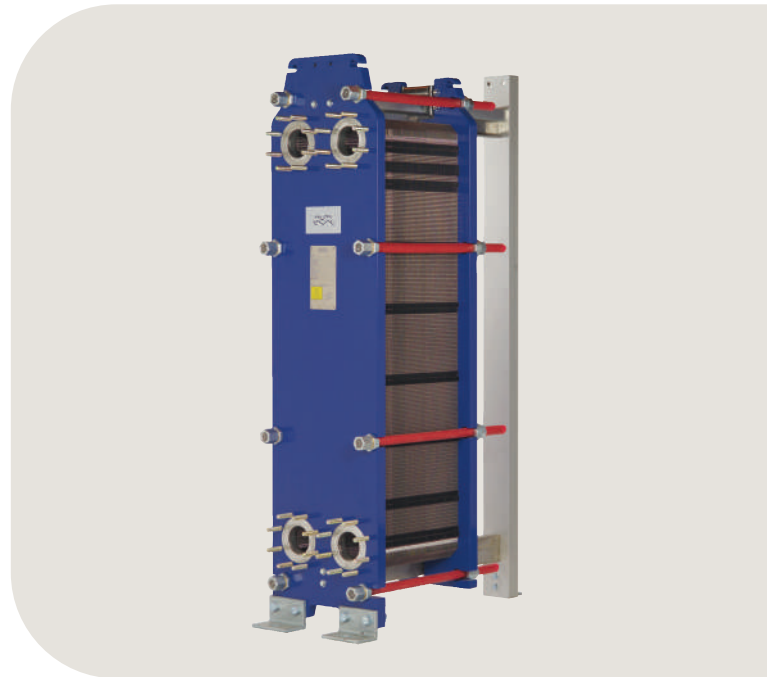

- Leak chamber
- Fixed bolt head
- Key hole bolt opening
- Lifting lug
- Lining
- Lock washer
- Pressure plate roller
- Tightening bolt cover

### Alfa Laval 360° Service Portfolio

Our extensive service offering ensure top performance from your Alfa Laval equipment throughout its life cycle. The Alfa Laval 360 Service Portfolio include installation services, cleaning and repair as well as spare parts, technical documentation and trouble shooting. We also offer replacement, retrofit, integrity testing, monitoring and much more.

For information about our complete service offering and how to contact us - please visit [www.alfalaval.com/service](http://www.alfalaval.com/service).

## General remarks for technical information

- The global offering presented in this leaflet may not be available for all regions
- All combinations may not be configurable

## Dimensional drawing

Measurements mm (inches)

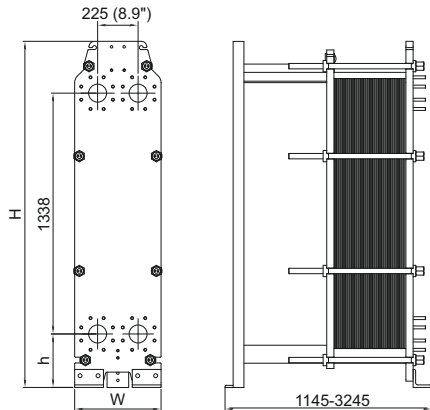

Frame type	H	W	h
FM	1885 (74.2")	480 (18.9")	255 (10.0")
FG	1981 (78.0")	480 (18.9")	297 (11.7")
FD	1981 (78.0")	480 (18.9")	297 (11.7")
FS	1981 (78.0")	510 (20.1")	297 (11.7")

The number of tightening bolts may vary depending on pressure rating.

## Technical data

Plates	Type	Free channel, mm (inches)
B	Single plate	2.0 (0.079)
P	Single plate	3.0 (0.12)

## Materials

Heat transfer plates	304/304L, 316/316L, 254 Alloy C276 Ni, Ti, TiPd
Field gaskets	NBR, EPDM, FKM, HeatSeal Carbon steel
Flange connections	Metal lined: stainless steel, Alloy 254, Alloy C276, nickel, titanium Rubber lined: NBR, EPDM
Frame and pressure plate	Carbon steel, epoxy painted

Other materials may be available on request.

## Operational data

Frame type	Max. design pressure barg (psig)	Max. design temperature °C (°F)
FM, PED		
FM, pvcALS	10.0 (145)	180 (356)
FG, pvcALS	16.0 (232)	180 (356)

Frame type	Max. design pressure barg (psig)	Max. design temperature °C (°F)
FG, ASME	10.3 (150)	250 (482)
FG, PED	16.0 (232)	180 (356)
FD, pvcALS	24.5 (355)	180 (356)
FD, PED	25.0 (362)	180 (356)
FS, ASME	27.6 (400)	250 (482)

Extended pressure and temperature rating may be available on request.

## Flange connections

Frame type	Connection standard
FM, pvcALS	EN 1092-1 DN100 PN10 ASME B16.5 Class 150 NPS 4 JIS B2220 10K 100A
FG, pvcALS	EN 1092-1 DN100 PN16 ASME B16.5 Class 150 NPS 4 JIS B2220 16K 100A
FG, Marine <sup>1</sup>	
FG, ASME	ASME B16.5 Class 150 NPS 4
FG, PED	EN 1092-1 DN100 PN16 ASME B16.5 Class 150 NPS 4 EN 1092-1 DN100 PN25
FD, pvcALS	ASME B16.5 Class 150 NPS 4 JIS B2220 20K 100A
FD, PED	EN 1092-1 DN100 PN25 ASME B16.5 Class 300 NPS 4 Special squared flange
FS, ASME	Special squared flange

<sup>1</sup> Marine includes the standards: ABS, BV, CCS, DNV, ClassNK, KR, LR, RINA, and RMRS.

Standard EN1092-1 corresponds to GOST 12815-80 and GB/T9124.1.

This document and its contents are subject to copyrights and other intellectual property rights owned by Alfa Laval AB (publ) or any of its affiliates (jointly "Alfa Laval"). No part of this document may be copied, re-produced or transmitted in any form or by any means, or for any purpose, without Alfa Laval's prior express written permission. Information and services provided in this document are made as a benefit and service to the user, and no representations or warranties are made about the accuracy or suitability of this information and these services for any purpose. All rights are reserved.

## How to contact Alfa Laval

Up-to-date Alfa Laval contact details for all countries are always available on our website at [www.alfalaval.com](http://www.alfalaval.com)



# Alfa Laval TL15

## Gasketed plate heat exchanger for a wide range of applications

### Introduction

Alfa Laval Industrial line is a wide product range that is used in virtually all types of industry.

The relatively tall plate makes this model suitable for duties with long temperature programs and when high heat recovery is appreciated. A large range of plate and gasket types is available.

### Applications

- Biotech and Pharmaceutical
- Chemicals
- Energy and Utilities
- Food, Dairy and Beverages
- Home and Personal care
- HVAC and Refrigeration
- Machinery and Manufacturing
- Marine and Transportation
- Mining, Minerals and Pigments
- Pulp and Paper
- Semiconductor and Electronics
- Steel
- Water and Waste treatment

### Benefits

- High energy efficiency – low operating cost
- Flexible configuration – heat transfer area can be modified
- Easy to install – compact design
- High serviceability – easy to open for inspection and cleaning and easy to clean by CIP
- Access to Alfa Laval's global service network

### Features

Every detail is carefully designed to ensure optimal performance, maximum uptime and easy maintenance. Selection of available features, depending on configuration some features may not be applicable:



- Five-point alignment
- Corner guided alignment system
- Chocolate pattern distribution area
- Clip-ad gasket
- Offset gasket groove
- Leak chamber



- Bearing boxes
- Fixed bolt head
- Key hole bolt opening
- Lifting lug
- Lining
- Lock washer
- Pressure plate roller
- Tightening bolt cover

### Alfa Laval 360° Service Portfolio

Our extensive service offering ensure top performance from your Alfa Laval equipment throughout its life cycle. The Alfa Laval 360 Service Portfolio include installation services, cleaning and repair as well as spare parts, technical documentation and trouble shooting. We also offer replacement, retrofit, integrity testing, monitoring and much more.

For information about our complete service offering and how to contact us - please visit [www.alfalaval.com/service](http://www.alfalaval.com/service).

## General remarks for technical information

- The global offering presented in this leaflet may not be available for all regions
- All combinations may not be configurable

## Dimensional drawing

Measurements mm (inches)

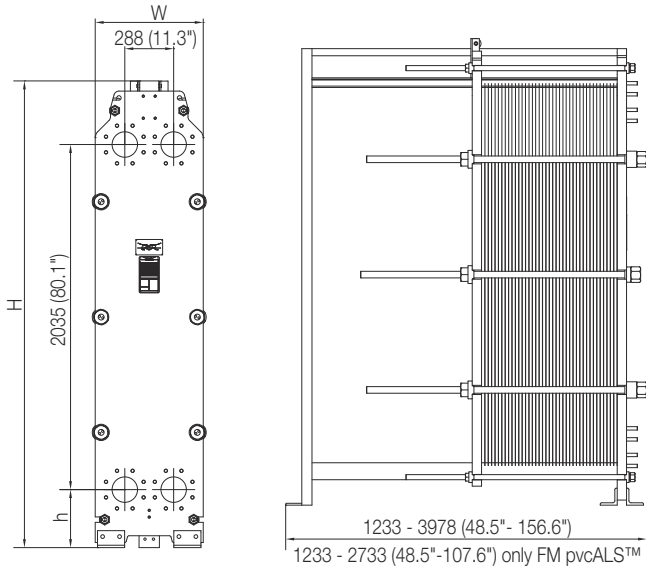

Frame type	H	W	h
FM	2752 (108.3")	610 (24.0")	342 (13.5")
FG	2752 (108.3")	637 (25.1")	342 (13.5")
FG, ASME	2752 (108.3")	646 (25.4")	342 (13.5")
FD, ASME	2752 (108.3")	646 (25.4")	342 (13.5")
FG	2752 (108.3")	646 (25.4")	342 (13.5")
FS, ASME	2752 (108.3")	646 (25.4")	342 (13.5")

## Technical data

Plates	Type	Free channel, mm (inches)
B	Single plate	1.9 (0.075)

## Materials

Heat transfer plates	304/304L, 316/316L Ti
Field gaskets	NBR, EPDM, HNBR
Flange connections	Metal lined: stainless steel, titanium Rubber lined: NBR, EPDM
Frame and pressure plate	Carbon steel, epoxy painted

Other materials may be available on request.

## Operational data

Frame type	Max. design pressure barg (psig)	Max. design temperature °C (°F)
FM, PED		
FM, pvcALS	10.0 (145)	180 (356)
FG, pvcALS	20.0 (290)	200 (392)
FG, ASME	10.3 (150)	250 (482)
FG, PED	20.0 (290)	200 (392)
FD, ASME	20.7 (300)	250 (482)
FS, pvcALS	35.0 (507)	200 (392)
FS, ASME	31.7 (460)	250 (482)
FS, PED	35.0 (507)	200 (392)

Extended pressure and temperature rating may be available on request.

## Flange connections

Frame type	Connection standard
FM, pvcALS	EN 1092-1 DN150 PN10
	ASME B16.5 Class 150 NPS 6
	JIS B2220 10K 150A
FG, pvcALS	EN 1092-1 DN150 PN16
	EN 1092-1 DN150 PN25
	ASME B16.5 Class 150 NPS 6
	JIS B2220 10K 150A
FG, ASME	JIS B2220 16K 150A
	ASME B16.5 Class 150 NPS 6
FG, PED	EN 1092-1 DN150 PN16
	EN 1092-1 DN150 PN25
FD, ASME	ASME B16.5 Class 300 NPS 6
	EN 1092-1 DN150 PN25
FS, pvcALS	EN 1092-1 DN150 PN40
	ASME B16.5 Class 400 NPS 6
	JIS B2220 10K 150A
	JIS B2220 20K 150A
FS, ASME	ASME B16.5 Class 400 NPS 6
	EN 1092-1 DN150 PN25
FS, PED	EN 1092-1 DN150 PN40
	ASME B16.5 Class 400 NPS 6
	ASME B16.5 Class 400 NPS 6

Standard EN1092-1 corresponds to GOST 12815-80 and GB/T9124.1.

This document and its contents are subject to copyrights and other intellectual property rights owned by Alfa Laval AB (publ) or any of its affiliates (jointly "Alfa Laval"). No part of this document may be copied, re-produced or transmitted in any form or by any means, or for any purpose, without Alfa Laval's prior express written permission. Information and services provided in this document are made as a benefit and service to the user, and no representations or warranties are made about the accuracy or suitability of this information and these services for any purpose. All rights are reserved.

## How to contact Alfa Laval

Up-to-date Alfa Laval contact details for all countries are always available on our website at [www.alfalaval.com](http://www.alfalaval.com)

# Alfa Laval TL35

## Gasketed plate heat exchanger for a wide range of applications

### Introduction

Alfa Laval Industrial line is a wide product range that is used in virtually all types of industry.

The relatively tall plate makes this model suitable for duties with long temperature programs and when high heat recovery is appreciated. A large range of plate and gasket types is available.

### Applications

- Biotech and Pharmaceutical
- Chemicals
- Energy and Utilities
- Food, Dairy and Beverages
- Home and Personal care
- HVAC and Refrigeration
- Machinery and Manufacturing
- Marine and Transportation
- Mining, Minerals and Pigments
- Pulp and Paper
- Semiconductor and Electronics
- Steel
- Water and Waste treatment

### Benefits

- High energy efficiency – low operating cost
- Flexible configuration – heat transfer area can be modified
- Easy to install – compact design
- High serviceability – easy to open for inspection and cleaning and easy to clean by CIP
- Access to Alfa Laval's global service network

### Features

Every detail is carefully designed to ensure optimal performance, maximum uptime and easy maintenance. Selection of available features, depending on configuration some features may not be applicable:



- Five-point alignment
- Reinforced hanger
- Chocolate pattern distribution area
- T-bar roller
- Glued gasket
- Clip-on gasket

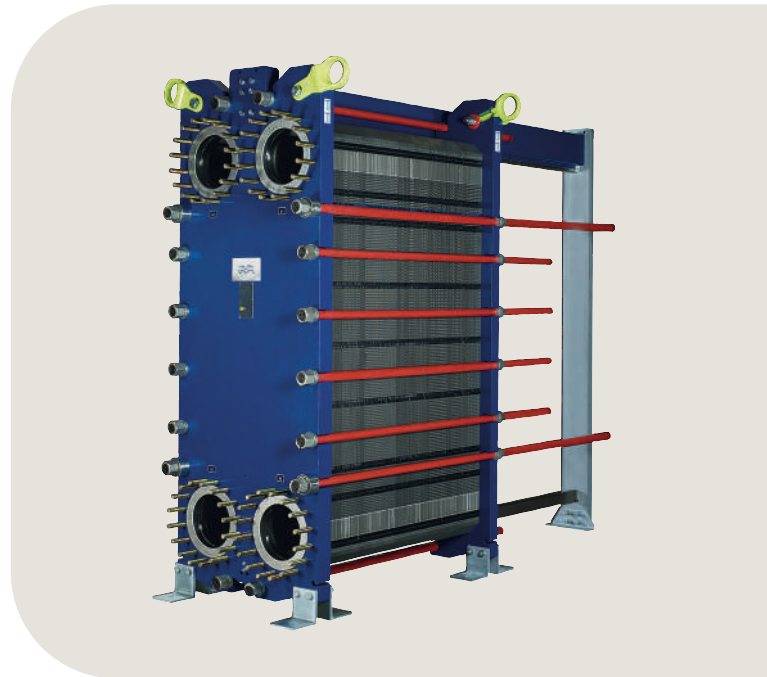

- Offset gasket groove
- Leak chamber
- Bearing boxes
- Fixed bolt head
- Key hole bolt opening
- Lifting lug
- Lining
- Lock washer
- Tightening bolt cover

### Alfa Laval 360° Service Portfolio

Our extensive service offering ensure top performance from your Alfa Laval equipment throughout its life cycle. The Alfa Laval 360 Service Portfolio include installation services, cleaning and repair as well as spare parts, technical documentation and trouble shooting. We also offer replacement, retrofit, integrity testing, monitoring and much more.

For information about our complete service offering and how to contact us - please visit [www.alfalaval.com/service](http://www.alfalaval.com/service).

## Dimensional drawing

Measurements mm (inches)

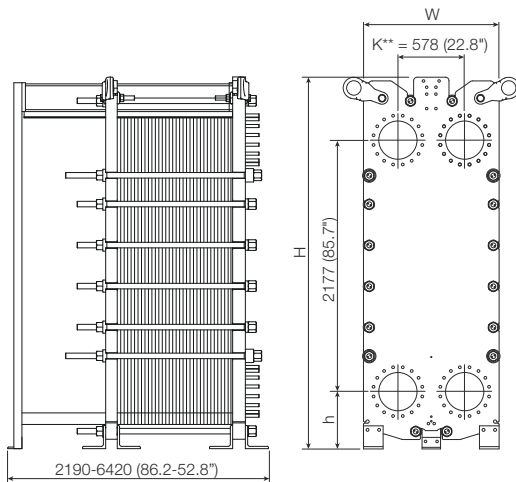

Frame type	H	W	h
FM	3210 (126.4")	1154 (45.4")	488 (19.2")
FG	3210 (126.4")	1154 (45.4")	488 (19.2")
FD	3218 (126.7")	1174 (46.2")	496 (19.5")
FS	3218 (126.7")	1174 (46.2")	496 (19.5")

### K\*\* = 578 mm (22.8") except for following

584 (23.0")	FS PED	Size 350 DN40
589 (23.2")	FD PED, pvcALS, ASME	Size 14" ASME class 300
589 (23.2")	FS PED, ASME	Size 14" ASME class 300 or 400

The number of tightening bolts may vary depending on pressure rating.

## Technical data

Plates	Type	Free channel, mm (inches)
B	Single plate	2.5 (0.098)

### Materials

Heat transfer plates	304/304L, 316/316L, 254, D205, Ni Alloy C276, Ti
Field gaskets	NBR, EPDM, FKM, HeatSeal
Flange connections	Carbon steel Metal lined: stainless steel, Alloy C-276, titanium
Frame and pressure plate	Carbon steel, epoxy painted

Other materials may be available on request.

## Operational data

Frame type	Max. design pressure barg (psig)	Max. design temperature °C (°F)
FM, PED	10.0 (145)	180 (356)
FM, pvcALS	10.0 (145)	180 (356)
FM, ASME	6.9 (100)	177 (350)
FG, pvcALS	16.0 (232)	180 (356)
FG, ASME	10.3 (150)	177 (350)
FG, PED	16.0 (232)	180 (356)
FD, pvcALS	25.0 (362)	160 (320)
FD, ASME	20.7 (300)	177 (350)
FD, PED	25.0 (362)	180 (356)
FS, ASME	27.6 (400)	177 (350)
FS, PED	30.0 (435)	180 (356)
FT, PED		

Extended pressure and temperature rating may be available on request.

## General remarks for technical information

- The global offering presented in this leaflet may not be available for all regions
- All combinations may not be configurable

## Flange connections

Frame type	Connection standard
FM, pvcALS	EN 1092-1 DN300 PN10
	EN 1092-1 DN350 PN10
	ASME B16.5 Class 150 NPS 12
	ASME B16.5 Class 150 NPS 14
	JIS B2220 10K 300A
FM, ASME	ASME B16.5 Class 150 NPS 12
	ASME B16.5 Class 150 NPS 14
FM, PED	EN 1092-1 DN300 PN10
	EN 1092-1 DN350 PN10
	ASME B16.5 Class 150 NPS 12
FG, pvcALS	ASME B16.5 Class 150 NPS 14
	EN 1092-1 DN300 PN16
	EN 1092-1 DN350 PN16
	ASME B16.5 Class 150 NPS 12
	ASME B16.5 Class 150 NPS 14
FG, Marine <sup>1</sup>	EN 1092-1 DN300 PN16
	EN 1092-1 DN350 PN16
	ASME B16.5 Class 150 NPS 12
FG, ASME	ASME B16.5 Class 150 NPS 14
	EN 1092-1 DN300 PN16
	EN 1092-1 DN350 PN16
	ASME B16.5 Class 150 NPS 12
	ASME B16.5 Class 150 NPS 14
FD, pvcALS	EN 1092-1 DN300 PN25
	EN 1092-1 DN350 PN25
	ASME B16.5 Class 300 NPS 12
	ASME B16.5 Class 300 NPS 14
	JIS B2220 20K 300A
FD, ASME	JIS B2220 20K 350A
	ASME B16.5 Class 300 NPS 12
	ASME B16.5 Class 300 NPS 14
FD, PED	FDc, ASME
	EN 1092-1 DN300 PN25
	EN 1092-1 DN350 PN25
	ASME B16.5 Class 300 NPS 12
	ASME B16.5 Class 300 NPS 14
FS, ASME	ASME B16.5 Class 300 NPS 12
	ASME B16.5 Class 300 NPS 14
	ASME B16.5 Class 400 NPS 12
	ASME B16.5 Class 400 NPS 14
	EN 1092-1 DN300 PN25
FS, PED	EN 1092-1 DN350 PN25
	EN 1092-1 DN300 PN40
	EN 1092-1 DN350 PN40
	ASME B16.5 Class 300 NPS 12
	ASME B16.5 Class 300 NPS 14
	ASME B16.5 Class 400 NPS 12
	ASME B16.5 Class 400 NPS 14

<sup>1</sup> Marine includes the standards: ABS, BV, CCS, DNV, ClassNK, KR, LR, RINA, and RMRS.

Standard EN1092-1 corresponds to GOST 12815-80 and GB/T9124.1.

# Alfa Laval TS6

## Gasketed plate heat exchanger for a wide range of applications

### Introduction

Alfa Laval Industrial line is a wide product range that is used in virtually all types of industry.

The relatively short plate makes this model suitable for duties with short temperature programs and when a low pressure drop is appreciated. A large range of plate and gasket types is available.

### Applications

- Biotech and Pharmaceutical
- Chemicals
- Energy and Utilities
- Food, Dairy and Beverages
- Home and Personal care
- HVAC and Refrigeration
- Machinery and Manufacturing
- Marine and Transportation
- Mining, Minerals and Pigments
- Pulp and Paper
- Semiconductor and Electronics
- Steel
- Water and Waste treatment

### Benefits

- High energy efficiency – low operating cost
- Flexible configuration – heat transfer area can be modified
- Easy to install – compact design
- High serviceability – easy to open for inspection and cleaning and easy to clean by CIP
- Access to Alfa Laval's global service network

### Features

Every detail is carefully designed to ensure optimal performance, maximum uptime and easy maintenance. Selection of available features, depending on configuration some features may not be applicable:

- Corner guided alignment system
- Chocolate pattern distribution area
- Clip-on gasket
- Leak chamber
- Fixed bolt head
- Key hole bolt opening
- Lifting lug
- Lining



- Lock washer
- Tightening bolt cover

### Alfa Laval 360° Service Portfolio

Our extensive service offering ensure top performance from your Alfa Laval equipment throughout its life cycle. The Alfa Laval 360 Service Portfolio include installation services, cleaning and repair as well as spare parts, technical documentation and trouble shooting. We also offer replacement, retrofit, integrity testing, monitoring and much more.

For information about our complete service offering and how to contact us - please visit [www.alfalaval.com/service](http://www.alfalaval.com/service).

## General remarks for technical information

- The global offering presented in this leaflet may not be available for all regions
- All combinations may not be configurable

## Dimensional drawing

Measurements mm (inches)

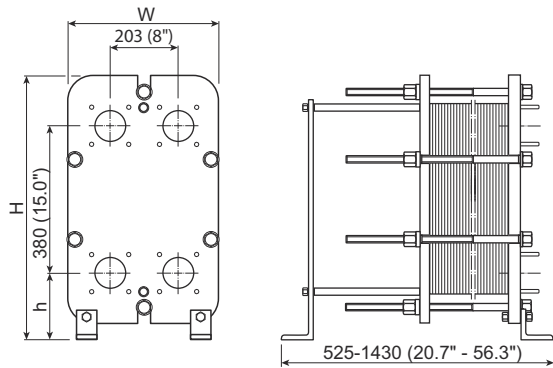

Frame type	H	W	h
FG	704 (27.7")	400 (15.7")	188 (7.4")
FD	704 (27.7")	410 (16.1")	188 (7.4")

## Technical data

Plates	Type	Free channel, mm (inches)
M	Single plate	4.0 (0.16)

## Materials

Heat transfer plates	316/316L Ti
Field gaskets	NBR, EPDM, FKM, HeatSeal
Flange connections	Carbon steel Metal lined: stainless steel, titanium
Frame and pressure plate	Carbon steel, epoxy painted

Other materials may be available on request.

## Operational data

Frame type	Max. design pressure barg (psig)	Max. design temperature °C (°F)
FG, pvcALS	16.0 (232)	180 (356)
FG, ASME	14.3 (207)	250 (482)
FG, PED	16.0 (232)	180 (356)
FD, pvcALS	24.5 (355)	200 (392)
FD, ASME	20.7 (300)	250 (482)
FD, PED	25.0 (362)	180 (356)

Extended pressure and temperature rating may be available on request.

## Flange connections

Frame type	Connection standard
FG, pvcALS	EN 1092-1 DN65 PN16
	JIS B2220 10K 65A
	JIS B2220 16K 65A
FG, Marine <sup>1</sup>	
FG, ASME	ASME B16.5 Class 150 NPS 3
FG, PED	EN 1092-1 DN65 PN16
	ASME B16.5 Class 150 NPS 3
FD, pvcALS	EN 1092-1 DN65 PN25
	JIS B2220 10K 65A
	JIS B2220 20K 65A
FD, ASME	ASME B16.5 Class 300 NPS 3
FDc, ASME	
FD, PED	EN 1092-1 DN65 PN25
	ASME B16.5 Class 300 NPS 3

<sup>1</sup> Marine includes the standards: ABS, BV, CCS, DNV, ClassNK, KR, LR, RINA, and RMRS.

Standard EN1092-1 corresponds to GOST 12815-80 and GB/T9124.1.

This document and its contents are subject to copyrights and other intellectual property rights owned by Alfa Laval AB (publ) or any of its affiliates (jointly "Alfa Laval"). No part of this document may be copied, re-produced or transmitted in any form or by any means, or for any purpose, without Alfa Laval's prior express written permission. Information and services provided in this document are made as a benefit and service to the user, and no representations or warranties are made about the accuracy or suitability of this information and these services for any purpose. All rights are reserved.

## How to contact Alfa Laval

Up-to-date Alfa Laval contact details for all countries are always available on our website at [www.alfalaval.com](http://www.alfalaval.com)

# Alfa Laval TS20

## Gasketed plate heat exchanger for a wide range of applications

### Introduction

Alfa Laval Industrial line is a wide product range that is used in virtually all types of industry.

The relatively short plate makes this model suitable for duties with short temperature programs and when a low pressure drop is appreciated. A large range of plate and gasket types is available.

### Applications

- Biotech and Pharmaceutical
- Chemicals
- Energy and Utilities
- Food, Dairy and Beverages
- Home and Personal care
- HVAC and Refrigeration
- Machinery and Manufacturing
- Marine and Transportation
- Mining, Minerals and Pigments
- Pulp and Paper
- Semiconductor and Electronics
- Steel
- Water and Waste treatment

### Benefits

- High energy efficiency – low operating cost
- Flexible configuration – heat transfer area can be modified
- Easy to install – compact design
- High serviceability – easy to open for inspection and cleaning and easy to clean by CIP
- Access to Alfa Laval's global service network

### Features

Every detail is carefully designed to ensure optimal performance, maximum uptime and easy maintenance. Selection of available features, depending on configuration some features may not be applicable:



- Five-point alignment
- Corner guided alignment system
- Chocolate pattern distribution area
- Glued gasket
- Clip-on gasket
- Leak chamber

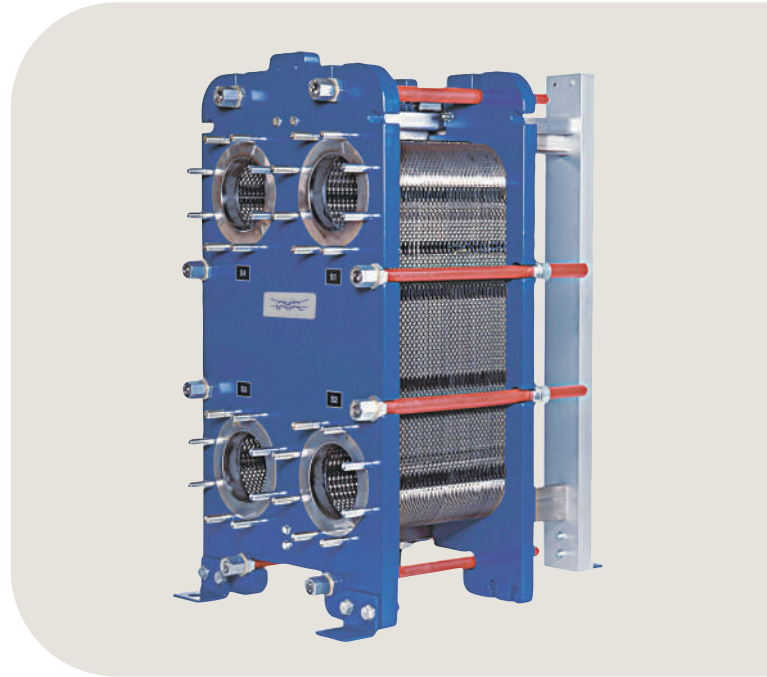

- Bearing boxes
- Fixed bolt head
- Key hole bolt opening
- Lifting lug
- Lining
- Lock washer
- Pressure plate roller
- Tightening bolt cover

### Alfa Laval 360° Service Portfolio

Our extensive service offering ensure top performance from your Alfa Laval equipment throughout its life cycle. The Alfa Laval 360 Service Portfolio include installation services, cleaning and repair as well as spare parts, technical documentation and trouble shooting. We also offer replacement, retrofit, integrity testing, monitoring and much more.

For information about our complete service offering and how to contact us - please visit [www.alfalaval.com/service](http://www.alfalaval.com/service).

## General remarks for technical information

- The global offering presented in this leaflet may not be available for all regions
- All combinations may not be configurable

## Dimensional drawing

Measurements mm (inches)

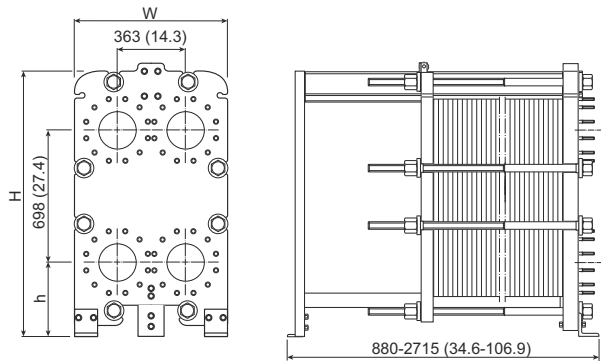

Frame type	H	W	h
FM	1405 (55.3")	740 (29.1")	360 (14.2")
FG	1405 (55.3")	800 (31.5")	360 (14.2")
FS	1435 (56.5")	800 (31.5")	390 (15.4")

The number of tightening bolts may vary depending on pressure rating.

## Technical data

Plates	Type	Free channel, mm (inches)
M	Single plate	4.0 (0.16)

### Materials

Heat transfer plates	316/316L, 254 C276, C2000 Ni, Ti, TiPd
Field gaskets	NBR, EPDM, FKM, HeatSeal Carbon steel
Flange connections	Metal lined: stainless steel, Alloy C-276, titanium Rubber lined: NBR, EPDM
Frame and pressure plate	Carbon steel, epoxy painted

Other materials may be available on request.

## Operational data

Frame type	Max. design pressure barg (psig)	Max. design temperature °C (°F)
FM, PED	10.0 (145)	210 (410)
FM, pvcALS	10.0 (145)	180 (356)
FG, pvcALS	16.0 (232)	180 (356)
FG, ASME	10.3 (150)	250 (482)
FG, PED	16.0 (232)	180 (356)
FS, ASME	31.7 (460)	250 (482)
FS, PED	30.0 (435)	210 (410)

Extended pressure and temperature rating may be available on request.

## Flange connections

Frame type	Connection standard
FM, pvcALS	EN 1092-1 DN200 PN10
	ASME B16.5 Class 150 NPS 8
	JIS B2220 10K 200A
FM, PED	EN 1092-1 DN200 PN10
	ASME B16.5 Class 150 NPS 8
FG, pvcALS	EN 1092-1 DN200 PN10
	ASME B16.5 Class 150 NPS 8
	JIS B2220 10K 200A
FG, ASME	ASME B16.5 Class 150 NPS 8
	EN 1092-1 DN200 PN16
FG, PED	ASME B16.5 Class 150 NPS 8
	ASME B16.5 Class 300 NPS 8
FS, ASME	EN 1092-1 DN200 PN25
	EN 1092-1 DN200 PN40
FS, PED	ASME B16.5 Class 300 NPS 8

Standard EN1092-1 corresponds to GOST 12815-80 and GB/T9124.1.

This document and its contents are subject to copyrights and other intellectual property rights owned by Alfa Laval AB (publ) or any of its affiliates (jointly "Alfa Laval"). No part of this document may be copied, re-produced or transmitted in any form or by any means, or for any purpose, without Alfa Laval's prior express written permission. Information and services provided in this document are made as a benefit and service to the user, and no representations or warranties are made about the accuracy or suitability of this information and these services for any purpose. All rights are reserved.

## How to contact Alfa Laval

Up-to-date Alfa Laval contact details for all countries are always available on our website at [www.alfalaval.com](http://www.alfalaval.com)

# Alfa Laval TS35

## Gasketed plate heat exchanger for a wide range of applications

### Introduction

Alfa Laval Industrial line is a wide product range that is used in virtually all types of industry.

The relatively short plate makes this model suitable for duties with short temperature programs and when a low pressure drop is appreciated. A large range of plate and gasket types is available.

### Applications

- Biotech and Pharmaceutical
- Chemicals
- Energy and Utilities
- Food, Dairy and Beverages
- Home and Personal care
- HVAC and Refrigeration
- Machinery and Manufacturing
- Marine and Transportation
- Mining, Minerals and Pigments
- Pulp and Paper
- Semiconductor and Electronics
- Steel
- Water and Waste treatment

### Benefits

- High energy efficiency – low operating cost
- Flexible configuration – heat transfer area can be modified
- Easy to install – compact design
- High serviceability – easy to open for inspection and cleaning and easy to clean by CIP
- Access to Alfa Laval's global service network

### Features

Every detail is carefully designed to ensure optimal performance, maximum uptime and easy maintenance. Selection of available features, depending on configuration some features may not be applicable:



- Five-point alignment
- Reinforced hanger
- T-bar roller
- CurveFlow™ distribution area
- Glued gasket
- PowerArc™ plate pattern divider



- ClipGrip™ gasket attachment
- Offset gasket groove
- OmegaPort™ noncircular port holes
- Leak chamber
- Bearing boxes
- Fixed bolt head
- Key hole bolt opening
- Lifting lug
- Lining
- Lock washer
- Swing feet
- Tightening bolt cover

### Alfa Laval service offering

Our vision is to be your trusted partner for service, driving sustainable performance together. The Alfa Laval portfolio of service offers for Plate Heat Exchangers from start-up of your operations, through operation, process improvements, and replacement. Throughout the lifecycle, we bring you more than 140 years of technical experience and innovative service

## General remarks for technical information

- The global offering presented in this leaflet may not be available for all regions
- All combinations may not be configurable

## Dimensional drawing

Measurements mm (inches)

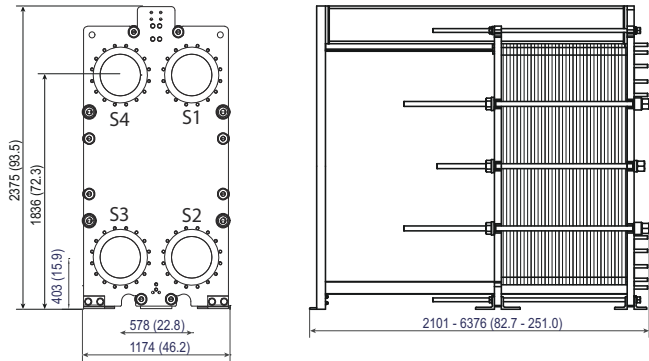

The number of tightening bolts may vary depending on pressure rating.

## Technical data

Plates	Type	Free channel, mm (inches)
P	Single plate	3.4 (0.13)

## Materials

	304/304L, 316/316L, 904L, 254 C276, C2000
Heat transfer plates	G30 Ti, TiPd Ti, TiPd
Field gaskets	NBR, EPDM, FKM, HeatSeal
Flange connections	Carbon steel Metal lined: stainless steel Alloy 316, titanium
Frame and pressure plate	Carbon steel, epoxy painted

Other materials may be available on request.

## Operational data

Frame type	Max. design pressure barg (psig)	Max. design temperature °C (°F)
FM, ALS	10.3 (150)	180 (356)
FM, Marine <sup>1</sup>	15 (218)	150 (302)
FG, pvcALS	16.0 (232)	180 (356)
FG, ASME	10.3 (150)	250 (482)
FG, PED	16.0 (232)	180 (356)
FD, pvcALS	25.0 (362)	180 (356)
FD, ASME	20.7 (300)	250 (482)
FD, PED	25.0 (362)	180 (356)
FS, ASME	27.6 (400)	250 (482)

<sup>1</sup> Marine includes the standards: ABS, BV, CCS, ClassNK, DNV, KR, LR, and RINA.

Extended pressure and temperature rating may be available on request.

## Flange connections

Frame type	Connection standard
FM, pvcALS	EN 1092-1 DN300 PN10
	EN 1092-1 DN350 PN10
	ASME B16.5 Class 150 NPS 12
	ASME B16.5 Class 150 NPS 14
	JIS B2220 10K 300A JIS B2220 10K 350A
FM, PED	EN 1092-1 DN300 PN10
	EN 1092-1 DN350 PN10
	ASME B16.5 Class 150 NPS 12
	ASME B16.5 Class 150 NPS 14
FM, Marine <sup>1</sup>	EN 1092-1 DN200 PN10
	ASME B16.5 Class 150 NPS 6
	JIS B2220 10K 300A JIS B2220 10K 350A
FG, pvcALS	EN 1092-1 DN300 PN16
	EN 1092-1 DN350 PN16
	ASME B16.5 Class 150 NPS 12
	ASME B16.5 Class 150 NPS 14
FG, Marine <sup>2</sup>	JIS B2220 16K 300A JIS B2220 16K 350A
	ASME B16.5 Class 150 NPS 12 ASME B16.5 Class 150 NPS 14
FG, PED	EN 1092-1 DN300 PN16
	EN 1092-1 DN350 PN16
FD, pvcALS	ASME B16.5 Class 150 NPS 12
	ASME B16.5 Class 150 NPS 14
	EN 1092-1 DN300 PN25
	EN 1092-1 DN350 PN25
	ASME B16.5 Class 300 NPS 12 ASME B16.5 Class 300 NPS 14 JIS B2220 20K 300A JIS B2220 20K 350A
FD, ASME	ASME B16.5 Class 300 NPS 12
	ASME B16.5 Class 300 NPS 14
FD, PED	EN 1092-1 DN300 PN25
	EN 1092-1 DN350 PN25
FS, ASME	ASME B16.5 Class 400 NPS 12
	ASME B16.5 Class 400 NPS 14

<sup>1</sup> Marine includes the standards: ABS, BV, CCS, DNV, ClassNK, KR, LR and RINA.

<sup>2</sup> Marine includes the standards: ABS, BV, CCS, DNV, ClassNK, KR, LR, and RINA.

Standard EN1092-1 corresponds to GOST 12815-80 and GB/T9124.1.

Extended connections are available for ASME B16.5 Class 150, Class 300, Class 400 size NPS 14.



# Alfa Laval TS45

## Gasketed plate heat exchanger for a wide range of applications

### Introduction

Alfa Laval Industrial line is a wide product range that is used in virtually all types of industry.

Designed for high throughput, this model delivers excellent thermal performance. A large selection of plate and gasket types is available.

### Applications

- Biotech and Pharmaceutical
- Chemicals
- Energy and Utilities
- Food, Dairy and Beverages
- Home and Personal care
- HVAC and Refrigeration
- Machinery and Manufacturing
- Marine and Transportation
- Mining, Minerals and Pigments
- Pulp and Paper
- Semiconductor and Electronics
- Water and Waste treatment

### Benefits

- High energy efficiency – low operating cost
- Flexible configuration – heat transfer area can be modified
- Easy to install – compact design
- High serviceability – easy to open for inspection and cleaning and easy to clean by CIP
- Access to Alfa Laval's global service network

### Features

Every detail is carefully designed to ensure optimal performance, maximum uptime and easy maintenance. Selection of available features, depending on configuration some features may not be applicable:



- Five-point alignment
- T-bar roller
- CurveFlow™ distribution area
- ClipGrip™ gasket attachment
- Offset gasket groove
- OmegaPort™ noncircular port holes
- Leak chamber
- FlexFlow™ plate design



- Bearing boxes
- Fixed bolt head
- Key hole bolt opening
- Lifting lug
- Lining
- Lock washer
- Tightening bolt cover

### Alfa Laval 360° Service Portfolio

Our extensive service offering ensure top performance from your Alfa Laval equipment throughout its life cycle. The Alfa Laval 360 Service Portfolio include installation services, cleaning and repair as well as spare parts, technical documentation and trouble shooting. We also offer replacement, retrofit, integrity testing, monitoring and much more.

For information about our complete service offering and how to contact us - please visit [www.alfalaval.com/service](http://www.alfalaval.com/service).

## General remarks for technical information

- The global offering presented in this leaflet may not be available for all regions
- All combinations may not be configurable

## Dimensional drawing

Measurements mm (inches)

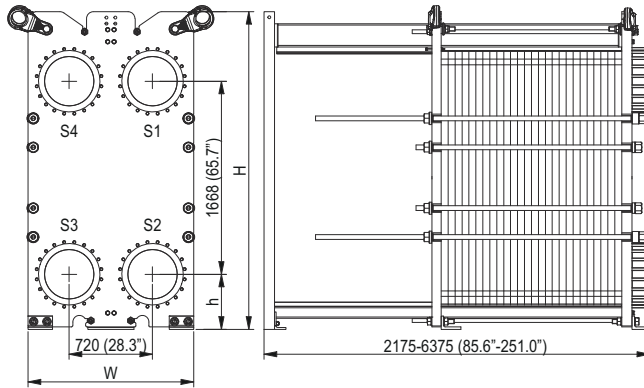

Frame type	H	W	h
FD	2745 (108.1")	1430 (56.3")	476 (18.7")
FG	2745 (108.1")	1430 (56.3")	476 (18.7")
FM	2745 (108.1")	1430 (56.3")	476 (18.7")

## Technical data

Plates	Type	Free channel, mm (inches)
M	Single plate	3.95 (0.155)
M	Single plate	N/A

## Materials

Heat transfer plates	304, 316, 254, Ti
Field gaskets	NBR, EPDM, FKM, HeatSeal
Flange connections	Carbon steel Metal lined: stainless steel, Alloy 254, titanium
Frame and pressure plate	Carbon steel, epoxy painted

Other materials may be available on request.

## Operational data

Frame type	Max. design pressure barg (psig)	Max. design temperature °C (°F)
FM, PED		
FM, pvcALS	11.0 (159)	200 (392)
FG, pvcALS	18.0 (261)	200 (392)
FG, ASME	10.4 (151)	250 (482)
FG, PED	18.5 (268)	200 (392)
FD, pvcALS	24.0 (348)	200 (392)
FD, ASME	21.4 (310)	250 (482)

Extended pressure and temperature rating may be available on request.

## Flange connections

Frame type	Connection standard
FM, pvcALS	EN 1092-1 DN450 PN10
	EN 1092-1 DN500 PN10
	ASME B16.5 Class 150 NPS 18 JIS B2220 10K 450A
FG, pvcALS	EN 1092-1 DN450 PN16
	ASME B16.5 Class 150 NPS 18 JIS B2220 16K 450A
FG, ASME	ASME B16.5 Class 150 NPS 18
FG, PED	EN 1092-1 DN450 PN16
	ASME B16.5 Class 150 NPS 18
FD, pvcALS	EN 1092-1 DN450 PN25
	ASME B16.5 Class 150 NPS 18
	ASME B16.5 Class 300 NPS 18 JIS B2220 20K 450A
FD, ASME	ASME B16.5 Class 300 NPS 18

Standard EN1092-1 corresponds to GOST 12815-80 and GB/T9124.1.

This document and its contents are subject to copyrights and other intellectual property rights owned by Alfa Laval AB (publ) or any of its affiliates (jointly "Alfa Laval"). No part of this document may be copied, re-produced or transmitted in any form or by any means, or for any purpose, without Alfa Laval's prior express written permission. Information and services provided in this document are made as a benefit and service to the user, and no representations or warranties are made about the accuracy or suitability of this information and these services for any purpose. All rights are reserved.

## How to contact Alfa Laval

Up-to-date Alfa Laval contact details for all countries are always available on our website at [www.alfalaval.com](http://www.alfalaval.com)

# Alfa Laval TS50

## Gasketed plate heat exchanger for a wide range of applications

### Introduction

Alfa Laval Industrial line is a wide product range that is used in virtually all types of industry.

Designed for high throughput, this model delivers excellent thermal performance. A large selection of plate and gasket types is available.

### Applications

- Biotech and Pharmaceutical
- Chemicals
- Energy and Utilities
- Food, Dairy and Beverages
- Home and Personal care
- HVAC and Refrigeration
- Machinery and Manufacturing
- Marine and Transportation
- Mining, Minerals and Pigments
- Pulp and Paper
- Semiconductor and Electronics
- Steel
- Water and Waste treatment

### Benefits

- High energy efficiency – low operating cost
- Flexible configuration – heat transfer area can be modified
- Easy to install – compact design
- High serviceability – easy to open for inspection and cleaning and easy to clean by CIP
- Access to Alfa Laval's global service network

### Features

Every detail is carefully designed to ensure optimal performance, maximum uptime and easy maintenance. Selection of available features, depending on configuration some features may not be applicable:



- Five-point alignment
- Reinforced hanger
- Chocolate pattern distribution area
- T-bar roller
- Glued gasket
- Base-ad gasket
- Leak chamber

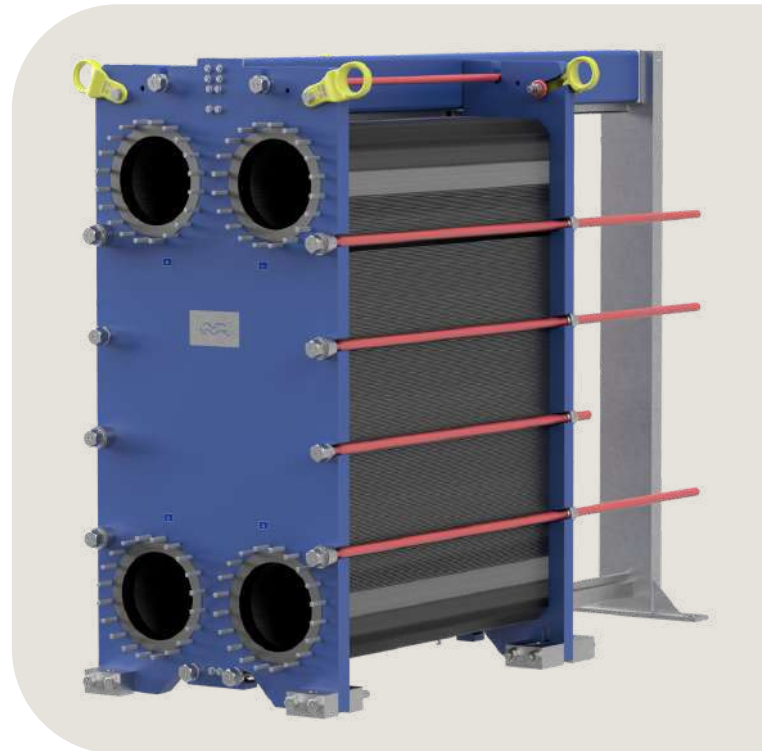

- Bearing boxes
- Fixed bolt head
- Key hole bolt opening
- Lifting lug
- Lining
- Lock washer
- Pressure plate roller
- Tightening bolt cover

### Alfa Laval 360° Service Portfolio

Our extensive service offering ensure top performance from your Alfa Laval equipment throughout its life cycle. The Alfa Laval 360 Service Portfolio include installation services, cleaning and repair as well as spare parts, technical documentation and trouble shooting. We also offer replacement, retrofit, integrity testing, monitoring and much more.

For information about our complete service offering and how to contact us - please visit [www.alfalaval.com/service](http://www.alfalaval.com/service).

## General remarks for technical information

- The global offering presented in this leaflet may not be available for all regions
- All combinations may not be configurable

## Dimensional drawing

Measurements mm (inches)

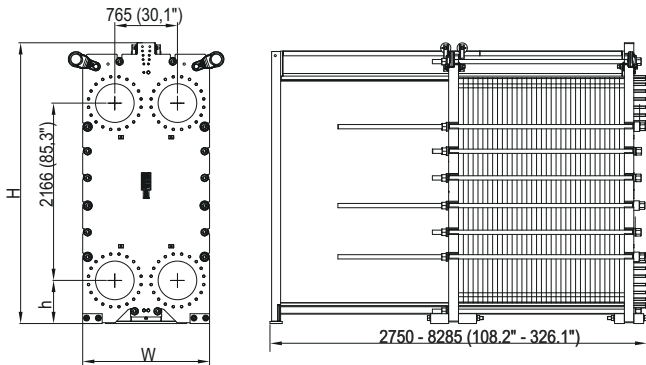

Frame type	H	W	h
FM	3330 (131.1")	1550 (61.0")	467 (18.4")
FG	3530 (138.9")	1550 (61.0")	467 (18.4")
FD	3530 (138.9")	1550 (61.0")	467 (18.4")

The number of tightening bolts may vary depending on pressure rating.

## Technical data

Plates	Type	Free channel, mm (inches)
M	Single plate	3.9 (0.15)

### Materials

Heat transfer plates	316, Ti
Field gaskets	NBR, EPDM, HNBR
Flange connections	Carbon steel Metal lined: stainless steel, titanium
Frame and pressure plate	Carbon steel, epoxy painted

Other materials may be available on request.

## Operational data

Frame type	Max. design pressure barg (psig)	Max. design temperature °C (°F)
FM, PED		
FM, pvcALS	11.0 (159)	200 (392)
FG, ASME	10.6 (153.7)	250 (482)
FG, PED	20.0 (290)	250 (482)
FD, ASME	21.4 (310)	250 (482)
FD, PED	31.3 (453.9)	250 (482)

Extended pressure and temperature rating may be available on request.

## Flange connections

Frame type	Connection standard
FM, pvcALS	EN 1092-1 DN500 PN10
	ASME B16.5 Class 150 NPS 20
	JIS B2220 10K 500A HG/T 20615 Class 150
FG, ASME	ASME B16.5 Class 150 NPS 20
FG, PED	EN 1092-1 DN500 PN10
	EN 1092-1 DN500 PN16 ASME B16.5 Class 150 NPS 20
FD, ASME	ASME B16.5 Class 150 NPS 20
	ASME B16.5 Class 300 NPS 20
FD, PED	EN 1092-1 DN500 PN25
	ASME B16.5 Class 300 NPS 20

Standard EN1092-1 corresponds to GOST 12815-80 and GB/T9124.1.

This document and its contents are subject to copyrights and other intellectual property rights owned by Alfa Laval AB (publ) or any of its affiliates (jointly "Alfa Laval"). No part of this document may be copied, re-produced or transmitted in any form or by any means, or for any purpose, without Alfa Laval's prior express written permission. Information and services provided in this document are made as a benefit and service to the user, and no representations or warranties are made about the accuracy or suitability of this information and these services for any purpose. All rights are reserved.

## How to contact Alfa Laval

Up-to-date Alfa Laval contact details for all countries are always available on our website at [www.alfalaval.com](http://www.alfalaval.com)