

Heavy Industrial Shock Absorbers

Effective shock absorption for heavy loads

The heavy industrial shock absorbers from ACE top off the company's offerings in damping technology. This ACE category gives Designers a choice between self-compensating and adjustable machine elements.

Whichever design is chosen, this type of shock absorber impresses with its robustness and operational readiness wherever heavy loads need to be reliably stopped on-the-spot and at a precise point.

The CA4 models can absorb up to 126,500 Nm of energy. The series of heavy duty, self-compensating "CA" types are equally suitable for use as an emergency stop as are the adjustable types with the designations "A". The range of effective loads covered is increased considerably for this purpose.



Heavy Industrial Shock Absorbers



CA2 to CA4

Self-Compensating

Deceleration of heavy loads

Portal systems, Machines and plants, Conveyor systems, Crane systems

Page 102



A1 1/2 to A3

Adjustable

Deceleration of heavy loads and progressive adjustment

Portal systems, Machines and plants, Conveyor systems, Crane systems

Page 106

Rugged and powerful

Gently stops heavy loads with high precision

Also ideal for emergency stop utilization

Safe, reliable production

Maintenance-free and ready-to-install

Special versions available



CA2 to CA4

Deceleration of heavy loads

Self-Compensating

Energy capacity 3,600 Nm/Cycle to 126,500 Nm/Cycle

Stroke 50 mm to 406 mm

Powerful: The weight of these high capacity absorbers are between 12.8 and 146 kg (28.2 lbs and 322 lbs.). They complement ACE's product range of self-compensating shock absorbers. All models from this product family are designed for applications where robustness and large energy absorption are important.

ACE uses our proprietary custom calculation program to design each shock absorber for the specific customer application. Customization helps reduce the risk of crashes and incorrect product sizing. The CA models can absorb up to 126,500 Nm (1,119,620 in-lbs) of energy and can be used in the area of effective weights between 700 kg and 326,000 kg (1,543 lbs and 718,707 lbs.). The combination of being extremely solid, absorbing high levels of energy and having a large damping range makes them invaluable. Self-compensating shock absorbers react to changing energy conditions, without adjustment.

These heavy duty self-compensating industrial shock absorbers are primarily used in heavy mechanical engineering e.g. on lift bridges and steel structures or for damping sluice systems.

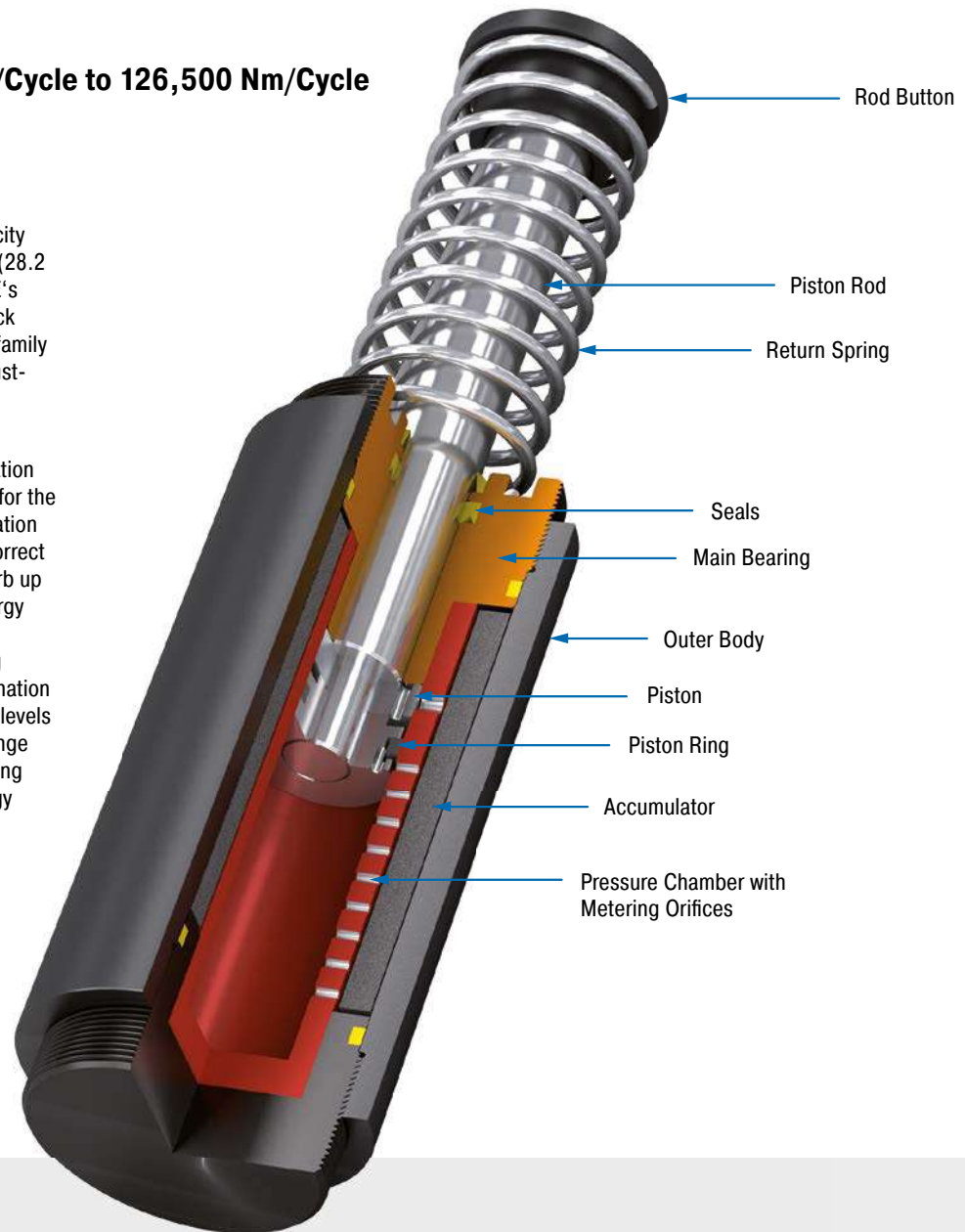

Technical Data

Energy capacity: 3,600 Nm/Cycle to 126,500 Nm/Cycle

Impact velocity range: 0.3 m/s to 5 m/s. Other speeds on request.

Operating temperature range: -12 °C to +66 °C. Other temperatures on request.

Mounting: In any position

Positive stop: External positive stops 2.5 mm to 3 mm before the end of stroke provided by the customer.

Material: Outer body: Steel corrosion-resistant coating; Piston rod: Hard chrome plated steel; Rod end button: Hardened steel and corrosion-resistant coating; Return spring: Zinc plated steel

Damping medium: Automatic Transmission Fluid (ATF)

Application field: Portal systems, Machines and plants, Conveyor systems, Crane systems, Loading and lifting equipment, Shelf storage systems, Heavy load applications, Swivel units

Note: For emergency use only applications and for continuous use it is possible to exceed the published max. capacity ratings. In this case, please consult ACE.

Safety information: External materials in the surrounding area can attack the seal components and lead to a shorter service life. Please contact ACE for appropriate solution sugges-

tions. Do not paint the shock absorbers due to heat emission.

On request: Special oils, nickel-plated, increased corrosion protection or other special options are available on request.

CA2-F Front Flange

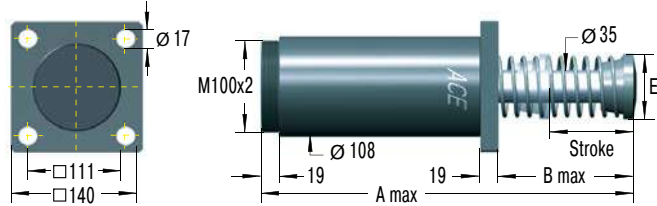

CA2-R Rear Flange

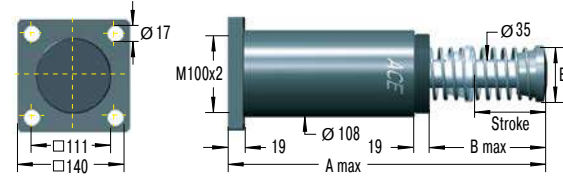

CA2-C Clevis Mount

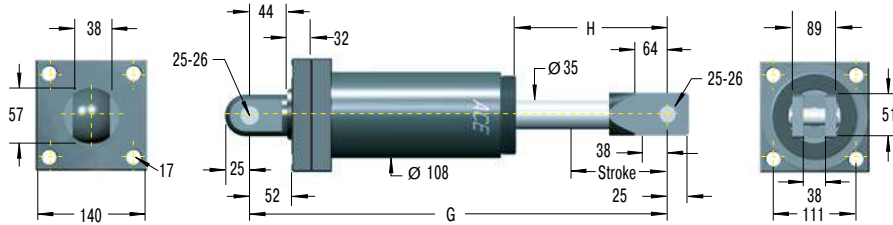

Model Type Prefix

Standard Models

CA: Self-contained with return spring, self-compensating

Special Models

CAA: Air/Oil return without return spring. Use only with external air/oil tank.

CNA: Self-Contained without return spring

CSA: Air/Oil return with return spring. Use only with external air/oil tank.

CA2-S 2" Bore Foot Mount

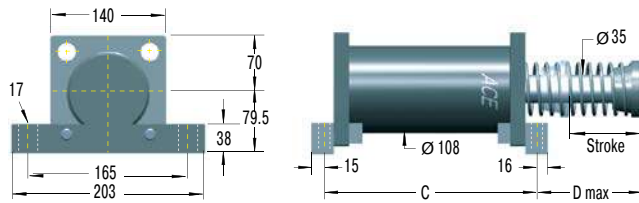

Ordering Example

Self-Compensating CA2x4F-3
 Bore Size \varnothing 2"
 Stroke Length 4" (102 mm)
 Front Flange Mounting
 Effective Weight Range Version

The calculation and selection of the most suitable damper should be carried out or be approved by ACE.

Dimensions

TYPES	Stroke mm	A max. mm	B max. mm	C mm	D max. mm	E mm
CA2X2	50	313	110	173	125	70
CA2X4	102	414	160	224	175	70
CA2X6	152	516	211	275	226	70
CA2X8	203	643	287	326	302	92
CA2X10	254	745	338	377	353	108

Performance

TYPES	Max. Energy Capacity			Effective Weight			Return Force min. N	Return Force max. N	Return Time s	Side Load Angle max. °	Weight kg
	¹ E ₃ Nm/cycle	² E ₄ Nm/h	² E ₄ with Air/Oil Tank Nm/h	³ We min. kg	³ We max. kg	Hardness					
CA2X2-1	3,600	1,100,000	1,350,000	700	2,200	-1	210	285	0.25	3	12.8
CA2X2-2	3,600	1,100,000	1,350,000	1,800	5,400	-2	210	285	0.25	3	12.8
CA2X2-3	3,600	1,100,000	1,350,000	4,500	13,600	-3	210	285	0.25	3	12.8
CA2X2-4	3,600	1,100,000	1,350,000	11,300	34,000	-4	210	285	0.25	3	12.8
CA2X4-1	7,200	1,350,000	1,700,000	1,400	4,400	-1	150	285	0.50	3	14.8
CA2X4-2	7,200	1,350,000	1,700,000	3,600	11,000	-2	150	285	0.50	3	14.8
CA2X4-3	7,200	1,350,000	1,700,000	9,100	27,200	-3	150	285	0.50	3	14.8
CA2X4-4	7,200	1,350,000	1,700,000	22,600	68,000	-4	150	285	0.50	3	14.8
CA2X6-1	10,800	1,600,000	2,000,000	2,200	6,500	-1	150	400	0.60	3	16.9
CA2X6-2	10,800	1,600,000	2,000,000	5,400	16,300	-2	150	400	0.60	3	16.9
CA2X6-3	10,800	1,600,000	2,000,000	13,600	40,800	-3	150	400	0.60	3	16.9
CA2X6-4	10,800	1,600,000	2,000,000	34,000	102,000	-4	150	400	0.60	3	16.9
CA2X8-1	14,500	1,900,000	2,400,000	2,900	8,700	-1	230	650	0.70	3	19.3
CA2X8-2	14,500	1,900,000	2,400,000	7,200	21,700	-2	230	650	0.70	3	19.3
CA2X8-3	14,500	1,900,000	2,400,000	18,100	54,400	-3	230	650	0.70	3	19.3
CA2X8-4	14,500	1,900,000	2,400,000	45,300	136,000	-4	230	650	0.70	3	19.3
CA2X10-1	18,000	2,200,000	2,700,000	3,600	11,000	-1	160	460	0.80	3	22.8
CA2X10-2	18,000	2,200,000	2,700,000	9,100	27,200	-2	160	460	0.80	3	22.8
CA2X10-3	18,000	2,200,000	2,700,000	22,600	68,000	-3	160	460	0.80	3	22.8
CA2X10-4	18,000	2,200,000	2,700,000	56,600	170,000	-4	160	460	0.80	3	22.8

¹ For emergency use only applications it is sometimes possible to exceed the above ratings. Please consult ACE for further details.

² Figures for oil recirculation systems on request.

³ The effective weight range limits can be raised or lowered to special order.

Self-Compensating

CA3-F Front Flange

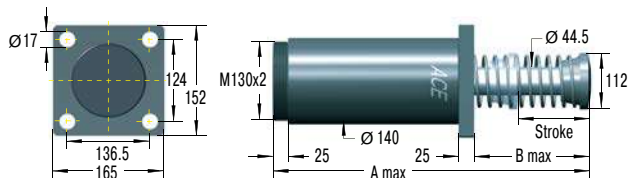

CA3-R Rear Flange

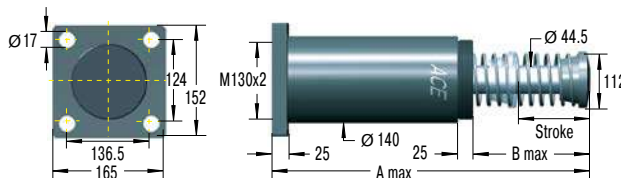

CA3-C Clevis Mount

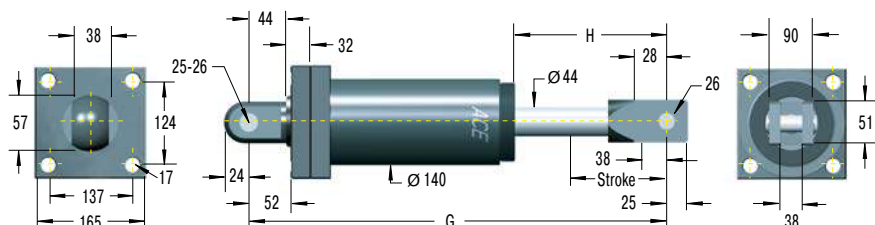

CA3-S Foot Mount

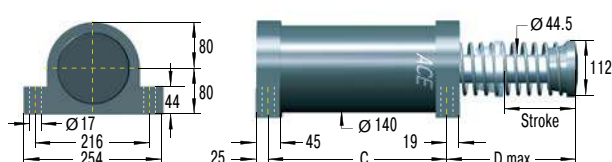

The calculation and selection of the most suitable damper should be carried out or be approved by ACE.

Model Type Prefix

Standard Models

CA: Self-contained with return spring, self-compensating

Special Models

CAA: Air/Oil return without return spring. Use only with external air/oil tank.

CNA: Self-Contained without return spring

CSA: Air/Oil return with return spring. Use only with external air/oil tank.

Ordering Example

Self-Compensating _____
 Bore Size Ø 3" _____
 Stroke Length 5" = 127 mm _____
 Effective Weight Range Version _____
 Front Flange Mounting _____

CA3x5-3F

Dimensions

TYPES	Stroke mm	A max. mm	B max. mm	C mm	D max. mm
CA3X5	127	490.5	211	254	224
CA3X8	203	641	286	330	300
CA3X12	305	890	434	432	447

Performance

TYPES	Max. Energy Capacity			Effective Weight			Return Force min. N	Return Force max. N	Return Time s	Side Load Angle max. °	Weight kg
	¹ E ₃ Nm/cycle	² E ₄ Nm/h	² E ₄ with Air/Oil Tank Nm/h	³ We min. kg	³ We max. kg	Hardness					
CA3X5-1	14,125	2,260,000	2,800,000	2,900	8,700	-1	270	710	0.6	3	28.9
CA3X5-2	14,125	2,260,000	2,800,000	7,250	21,700	-2	270	710	0.6	3	28.9
CA3X5-3	14,125	2,260,000	2,800,000	18,100	54,350	-3	270	710	0.6	3	28.9
CA3X5-4	14,125	2,260,000	2,800,000	45,300	135,900	-4	270	710	0.6	3	28.9
CA3X8-1	22,600	3,600,000	4,520,000	4,650	13,900	-1	280	740	0.8	3	33.4
CA3X8-2	22,600	3,600,000	4,520,000	11,600	34,800	-2	280	740	0.8	3	33.4
CA3X8-3	22,600	3,600,000	4,520,000	29,000	87,000	-3	280	740	0.8	3	33.4
CA3X8-4	22,600	3,600,000	4,520,000	72,500	217,000	-4	280	740	0.8	3	33.4
CA3X12-1	33,900	5,400,000	6,780,000	6,950	20,900	-1	270	730	1.2	3	40.6
CA3X12-2	33,900	5,400,000	6,780,000	17,400	52,200	-2	270	730	1.2	3	40.6
CA3X12-3	33,900	5,400,000	6,780,000	43,500	130,450	-3	270	730	1.2	3	40.6
CA3X12-4	33,900	5,400,000	6,780,000	108,700	326,000	-4	270	730	1.2	3	40.6

¹ For emergency use only applications it is sometimes possible to exceed the above ratings. Please consult ACE for further details.

² Figures for oil recirculation systems on request.

³ The effective weight range limits can be raised or lowered to special order.

A1 1/2 to A3

Deceleration of heavy loads and progressive adjustment

Adjustable

Energy capacity 2,350 Nm/Cycle to 44,000 Nm/Cycle

Stroke 50 mm to 305 mm

Strong and adjustable: Also in ACE's range of units are heavy duty industrial shock absorbers, which can be adjusted. The models from the A1 1/2 to A3 range, which weigh between 7.55 kg and 48 kg, are extremely robust, ready-to-install hydraulic machine elements with impressively high energy absorption levels and a wide range of damping rates.

Their special aspect is the flexibility, as all the absorbers can be adjusted using a socket on the absorber base and be perfectly adapted to the required data. The A models cover a range of effective loads from 0.3 kg to 204,000 kg and can absorb up to 44,000 Nm energy.

These heavy duty, adjustable ACE industrial shock absorbers are the first choice in heavy duty applications and generally in heavy mechanical engineering when the usage data has not been exactly determined.

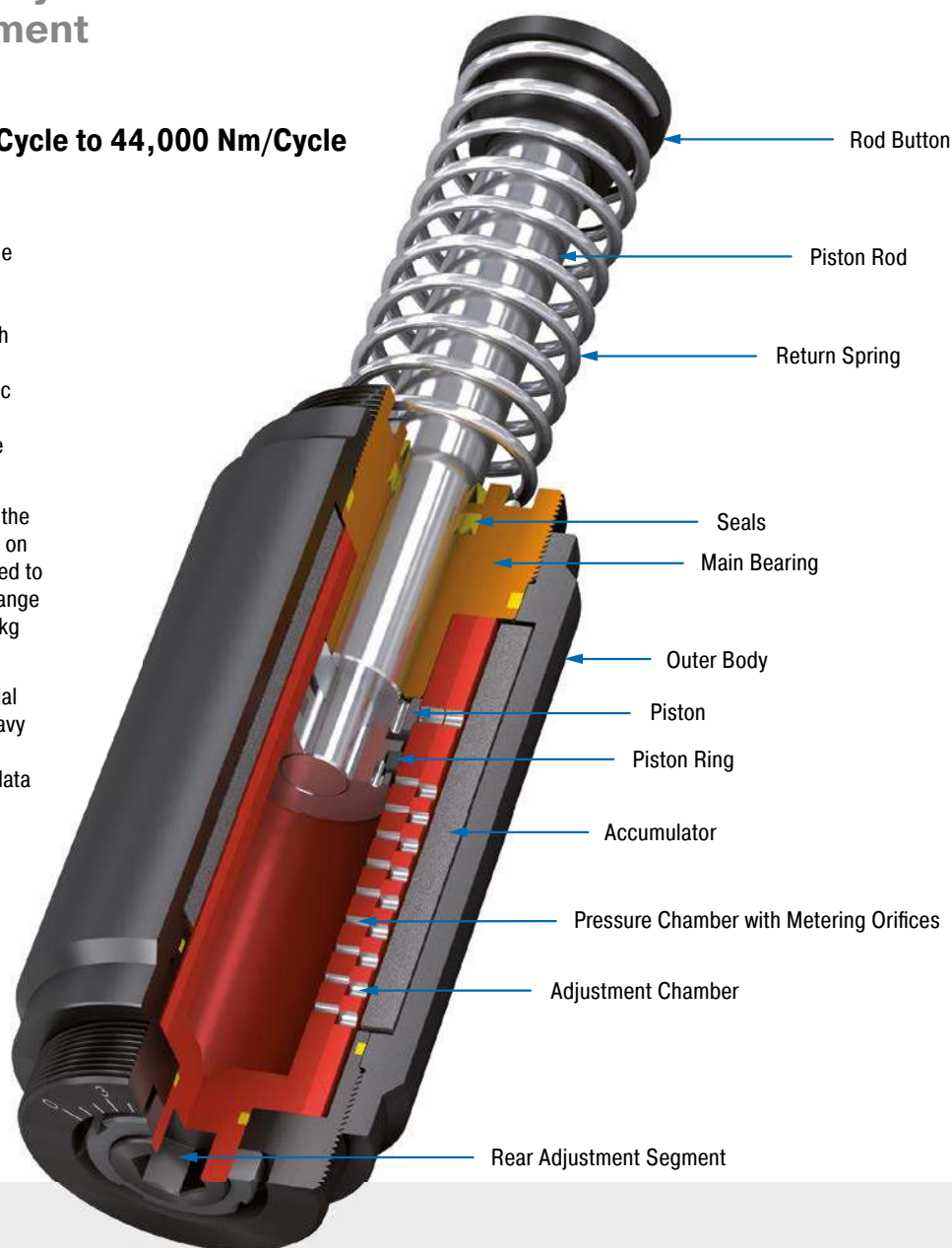

Technical Data

Energy capacity: 2,350 Nm/Cycle to 44,000 Nm/Cycle

Impact velocity range: 0.1 m/s to 5 m/s. Other speeds on request.

Operating temperature range: -12 °C to +66 °C. Other temperatures on request.

Mounting: In any position

Positive stop: External positive stops 2.5 mm to 3 mm before the end of stroke provided by the customer.

Adjustment: Hard impact at the start of stroke, adjust the ring towards 9. Hard impact at the end of stroke, adjust the ring towards 0.

Material: Outer body: Steel corrosion-resistant coating; Piston rod: Hard chrome plated steel; Rod end button: Hardened steel and corrosion-resistant coating; Return spring: Zinc plated steel

Damping medium: Automatic Transmission Fluid (ATF)

Application field: Portal systems, Machines and plants, Conveyor systems, Crane systems, Loading and lifting equipment, Impact panels, Heavy load applications, Swivel units, Shelf storage systems

Note: For emergency use only applications and for continuous use it is possible to exceed

the published max. capacity ratings. In this case, please consult ACE.

Safety information: External materials in the surrounding area can attack the seal components and lead to a shorter service life. Please contact ACE for appropriate solution suggestions. Do not paint the shock absorbers due to heat emission.

On request: Special oils, nickel-plated, increased corrosion protection or other special options are available on request.

A1 1/2-F Front Flange



A1 1/2-R Rear Flange



A1 1/2-C Clevis Mount

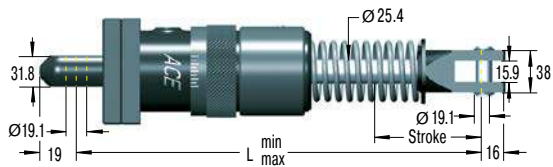

A1 1/2-S Foot Mount



The calculation and selection of the most suitable damper should be carried out or be approved by ACE.

Model Type Prefix

Standard Models

A: Self-contained with return spring, adjustable

Special Models

AA: Air/Oil return without return spring. Use only with external air/oil tank.

NA: Self-contained without return spring

SA: Air/Oil return with return spring. Use only with external air/oil tank.

Ordering Example

Adjustable A1 1/2x2R
 Bore Size $\varnothing 1\frac{1}{2}$ "
 Stroke Length 2" (50.8 mm)
 Rear Flange Mounting

Dimensions

TYPES	Stroke mm	L min. mm	L max. mm	L1 mm	L2 mm	L3 mm	L4 mm
A11/2X2	50	277.8	328.6	195.2	54.2	-	-
A11/2X31/2	89	316.6	405.6	233	54.2	170	58.6
A11/2X5	127	354.8	481.8	271.5	54.2	208	58.6
A11/2X61/2	165	412	577	329	73	246	78

Performance

TYPES	Max. Energy Capacity			Effective Weight		Return Force min. N	Return Force max. N	Return Time s	Side Load Angle max. °	Weight kg
	¹ E ₃ Nm/cycle	² E ₄ Nm/h	² E ₄ with Air/Oil Tank Nm/h	³ We min. kg	³ We max. kg					
A11/2X2	2,350	362,000	452,000	195	32,000	160	210	0.10	5	7.6
A11/2X31/2	4,150	633,000	791,000	218	36,000	110	210	0.25	4	8.9
A11/2X5	5,900	904,000	1,130,000	227	41,000	90	230	0.40	3	9.4
A11/2X61/2	7,700	1,180,000	1,469,000	308	45,000	90	430	0.40	2	12.0

¹ For emergency use only applications it is sometimes possible to exceed the above ratings. Please consult ACE for further details.

² Figures for oil recirculation systems on request.

³ The effective weight range limits can be raised or lowered to special order.

Adjustable

A2-F Front Flange

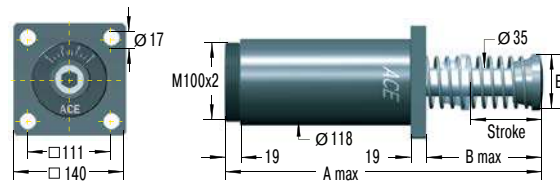

A2-R Rear Flange

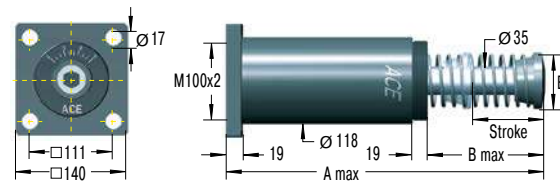

A2-C Clevis Mount

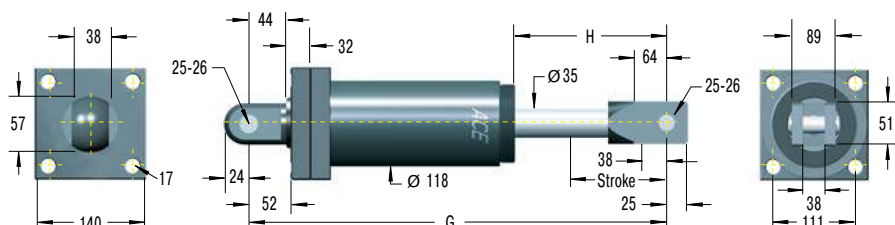

A2-S 2" Bore Foot Mount

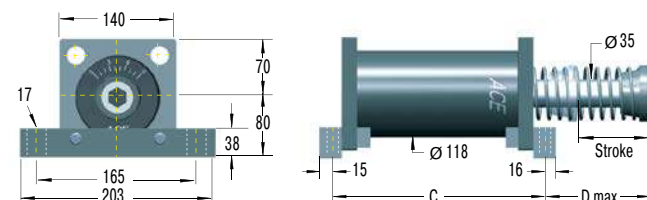

The calculation and selection of the most suitable damper should be carried out or be approved by ACE.

Model Type Prefix

Standard Models

A: Self-contained with return spring, adjustable

Special Models

AA: Air/Oil return without return spring. Use only with external air/oil tank.

NA: Self-contained without return spring

SA: Air/Oil return with return spring. Use only with external air/oil tank.

Ordering Example

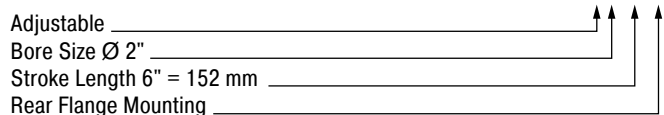

Dimensions

TYPES	Stroke mm	A max. mm	B max. mm	C mm	D max. mm	E mm
A2X2	50	313	110	173	125	70
A2X4	102	414	160	224	175	70
A2X6	152	516	211	275	226	70
A2X8	203	643	287	326	302	92
A2X10	254	745	338	377	353	108

Performance

TYPES	Max. Energy Capacity			Effective Weight		Return Force min. N	Return Force max. N	Return Time s	Side Load Angle max. °	Weight kg
	¹ E ₃ Nm/cycle	² E ₄ Nm/h	² E ₄ with Air/Oil Tank Nm/h	³ We min. kg	³ We max. kg					
A2X2	3,600	1,100,000	1,350,000	250	77,000	210	285	0.25	3	14.3
A2X4	9,000	1,350,000	1,700,000	250	82,000	150	285	0.50	3	16.7
A2X6	13,500	1,600,000	2,000,000	260	86,000	150	400	0.60	3	19.3
A2X8	19,200	1,900,000	2,400,000	260	90,000	230	650	0.70	3	22.3
A2X10	23,700	2,200,000	2,700,000	320	113,000	160	460	0.80	3	26.2

¹ For emergency use only applications it is sometimes possible to exceed the above ratings. Please consult ACE for further details.

² Figures for oil recirculation systems on request.

³ The effective weight range limits can be raised or lowered to special order.



A3-F Front Flange

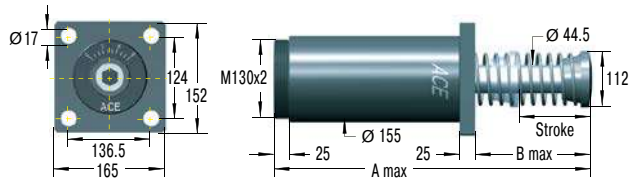

A3-R Rear Flange

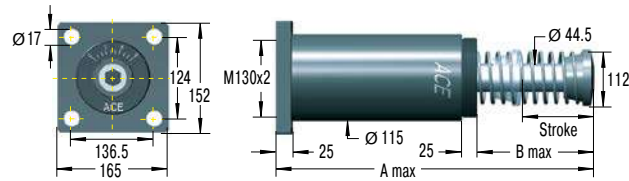

A3-C Clevis Mount

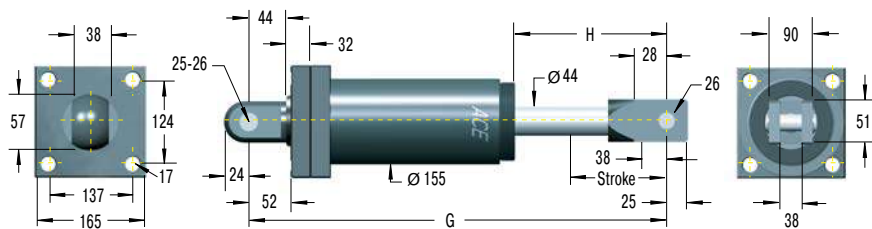

A3-S Foot Mount

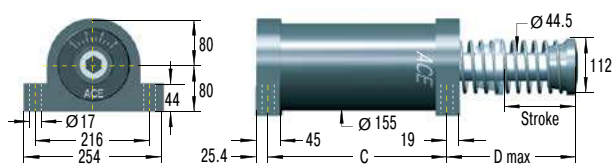

The calculation and selection of the most suitable damper should be carried out or be approved by ACE.

Model Type Prefix

Standard Models

A: Self-contained with return spring, adjustable

Special Models

AA: Air/Oil return without return spring. Use only with external air/oil tank.

NA: Self-contained without return spring

SA: Air/Oil return with return spring. Use only with external air/oil tank.

Ordering Example

Adjustable _____ **A3x8R**
 Bore Size \varnothing 3" _____
 Stroke Length 8" (203 mm) _____
 Rear Flange Mounting _____

Dimensions

TYPES	Stroke mm	A max. mm	B max. mm	C mm	D max. mm
A3X5	127	490.5	211	254	224
A3X8	203	641	286	330	300
A3X12	305	890	434	432	447

Performance

TYPES	Max. Energy Capacity			Effective Weight		Return Force min. N	Return Force max. N	Return Time s	Side Load Angle max. °	Weight kg
	¹ E ₃ Nm/cycle	² E ₄ Nm/h	² E ₄ with Air/Oil Tank Nm/h	³ We min. kg	³ We max. kg					
A3X5	15,800	2,260,000	2,800,000	480	154,000	270	710	0.6	3	32.7
A3X8	28,200	3,600,000	4,520,000	540	181,500	280	740	0.8	3	38.5
A3X12	44,000	5,400,000	6,780,000	610	204,000	270	730	1.2	3	48.0

¹ For emergency use only applications it is sometimes possible to exceed the above ratings. Please consult ACE for further details.

² Figures for oil recirculation systems on request.

³ The effective weight range limits can be raised or lowered to special order.

Air/Oil Tanks for industrial shock absorbers

For high cycle rates and extreme temperatures with limited mounting space

Shock absorbers convert the introduced energy into heat. The more frequently a shock absorber is stressed per hour, the hotter the oil volume becomes over time. If the requirements placed on the impact frequency of a shock absorber are especially high, use of an air-oil tank is the solution.

Thanks to increased oil volume and resulting heat dissipation, the upper limit of the possible hourly energy capacity of the shock absorber increases significantly.

In addition, the air-oil tank provides an opportunity for controlled piston return if no permanent return force through an integrated spring in the shock absorber is desired.

Air/Oil Tanks AO

A01

Oil capacity 20 cm³
Material: Aluminium caps

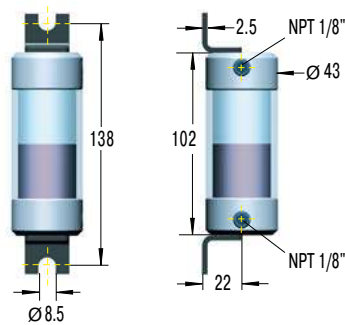

Detail drawings on request

A03

Oil capacity 370 cm³
Material: Steel



A06

Oil capacity 2,600 cm³
Material: Steel

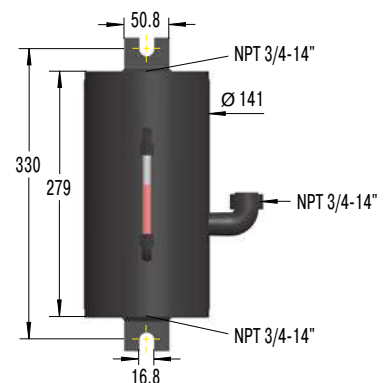

Technical Data

Operating pressure: Max. 8 bar (116 psi)
Operating temperature range: 80 °C
Damping medium: ATF-Oil 42 cSt at 40 °C
Mount air/oil tank higher than shock absorber.
Bleed all air from system before operating.

Safety instructions: Exhaust tank before carrying out service. Check valve holds pressure!

Suggested air/oil tanks in accordance with E₄ ratings

Connection Examples

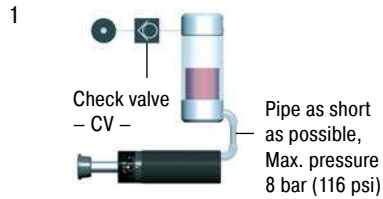

Piston rod returns immediately to extended position when load moves away. Operation without main air supply possible for short periods.



Return stroke may be sequenced by pneumatic valve at any desired time. No return force until valve energised.

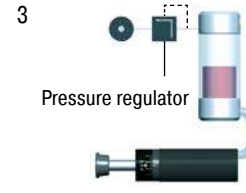

Return force can be adjusted by pressure regulator. Ensure safe minimum pressure to return shock absorber.



Spring return with air/oil tank. No air supply connected. Note: Will extend return time.

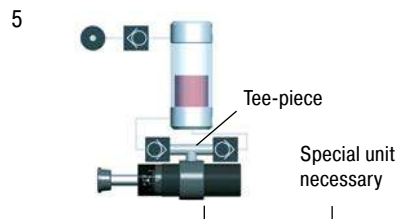

Oil recirculation circuit for extreme high cycle rates. Warm oil is positively circulated through air/oil tank for increased heat dissipation.

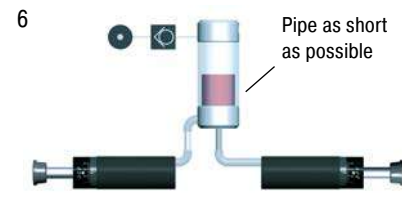

Connection of two shock absorbers to one air/oil tank is possible. Use next larger size tank. Combination with examples 2, 3 and 5 possible.

Selection Chart Air/Oil Tanks

Shock Absorber Type	With Tank Example 1 to 4		With Recirc. Circuits Example 5 to 6		Min. Conn. Pipe Ø mm	Thread Sizes for Connection to Air/Oil Tank	
	Tank	Check Valve	Tank	Check Valve		Thread Bottom	² Thread Side
MCA, MAA, MLA33...	AO1	CV1/8	AO3	CV1/4	4	¹ 1/8-27 NPTF inside	1/8-27 NPTF inside
MCA, MAA, MLA45...	AO1	CV1/8	AO3	CV3/8	6	1/8-27 NPTF inside	1/8-27 NPTF inside
MCA, MAA, MLA64...	AO3	CV1/4	AO6	CV3/4	8	1/4-18 NPTF inside	1/4-18 NPTF inside
CAA, AA2...	AO6	CV3/4	AO82	CV3/4	15	–	–
CAA, AA3...	AO6	CV3/4	AO82	CV3/4	19	–	–
CAA4...	AO82	CV3/4	AO82	CV3/4	38	–	–

AO82 and connection accessories: Details on request

¹ adapted

² on request (add suffix -PG/-P)

Check Valves CV

Through an oil circuit fresh oil is drawn in from the industrial shock absorber and warm oil is pumped off (see example 5). To obtain this function, ACE offers suitable check valves of the CV series.

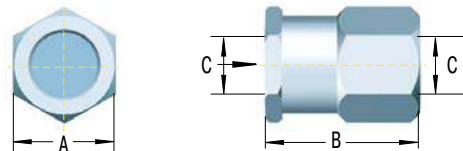

Technical Data

Operating pressure: 20 bar (290 psi)

Operating temperature range: 95 °C

Suitable for: Oil, air, water

Material: Aluminium

Check Valves – Dimensions			
TYPES	A mm	B mm	C
CV1/8	19	24	1/8-27 NPT
CV1/4	29	33	1/4-18 NPT
CV3/8	29	33	3/8-18 NPT
CV1/2	41	40	1/2-14 NPT
CV3/4	48	59	3/4-14 NPT